

TECHNISCHE DATEN • technical data • dati tecnici • caractéristiques techniques

Breite (Einbaumaß Korpus) **550 mm**
width (fitting measure body) • larghezza • largeur (dimension du corps de l'appareil)

Türrahmenhöhe **510 / 570 / 680 mm**
height doorframe • altezza antina • hauteur du cadre de porte

Türformen **Ecke 90° • corner 90° • angolo 90° • angle 90°**
door • versione antina • forme de la porte

Breite **579 mm**
width • larghezza • largeur

Tiefe **579 mm**
depth • profondità • profondeur

Höhe **1230-1430 / 1290-1490 / 1400-1600 mm**
height • altezza • hauteur

Gewicht **105 / 109 / 117 kg**
weight • peso • poids

Nennwärmeleistung lt. EN 133329 **7 kW**
nominal heat output according to EN • resa nominale secondo norme EN • puissance de chauffage selon EN

min. / max. Heizleistung **3,5-9 kW**
min. / max. heat output • potenzialità termica effettiva • puissance de chauffage

Rauchrohrabgang **Ø 180 mm**
flue pipe outlet • diametro uscita fumi • sortie de tuyau de fumées

Abgasmassenstrom **7,5 g/s**
flue gas mass flow • flusso fumi • flux massique de gaz d'échappement

Abgastemperatur **330 °C**
flue gas temperature • temperatura fumi • température de gaz d'échappement

Mindestförderdruck **12 Pa**
minimum feed pressure • depressione min. necessaria • pression de transport minimum

Umluftquerschnitt ohne / mit metallischer Nachheizfläche **700 / 1100 cm²**
convection air cross section without/with metallic heat exchanger • sezione trasversale aria convettiva senza/con scambiatore di calore metallico • section arrivée d'air sans / avec surface de chauffe métallique

Dämmschichtdicken Promasil 950 KS (Boden / Seite / hinten / Decke*) **0 / 60 / 60 mm**
insulation thickness Promasil 950 KS (floor / sides / rear / ceiling*) • spessore isolante Promasil 950 KS - silicato di calcio (inferiore / laterale / posteriore / superiore*) • épaisseurs d'isolant Promasil 950 KS (sol / côté / arrière / en haut*)

Geschlossene Anlage möglich **ja • yes • si • oui**
closed construction possible • installazione ermetica possibile • installation hermétique possible

Keramische Züge: Länge maximal **4 m**
connection to ceramic flue heat exchangers: length max. • convogliamento in scambiatore ceramico: lungo massimo / refrattario • circulation d'air chaud dans canalisation céramique: longueur max.

Klapptüre
hinged door • apertura a battente • porte ouverture latérale
Anschlag von links auf rechts wechselbar • door rabbet can be exchanged from left to right • huisserie de la porte peut être mise de gauche à droite

Doppelscheibe
double glass • doppio vetro • double vitrage

* laut landesüblicher Installationsnormen • specification concerning fire prevention and thermal insulation • in ottemperanza con le normative locali vigenti • selon les normes d'installation régionales en vigueur



Art. no. 3600019

Maßstab 1:20

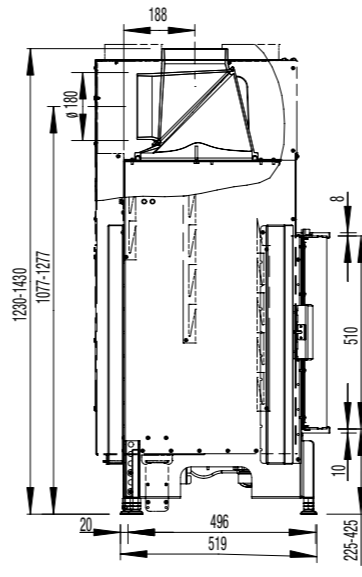
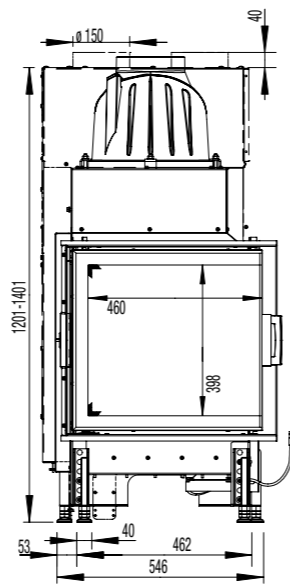

Maßstab 1:10

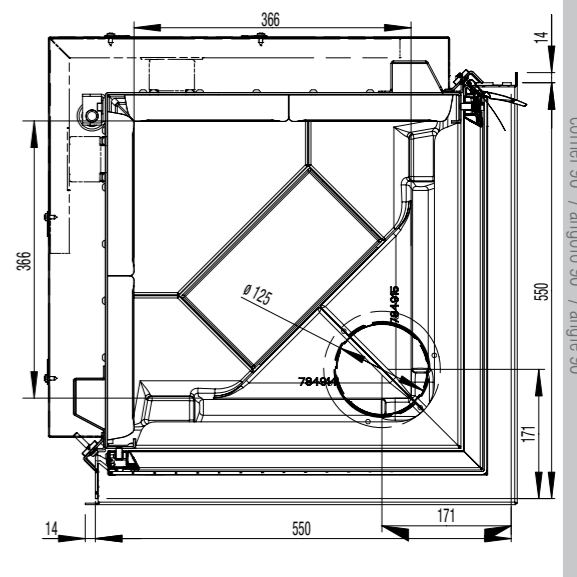
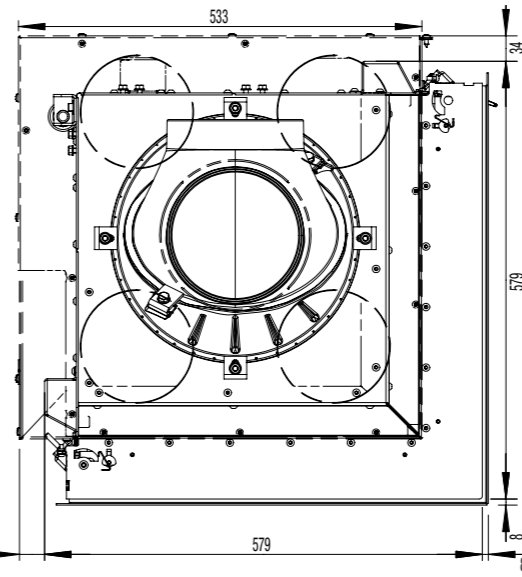

510 Ecke 90°
corner 90° / angolo 90° / angle 90°



Art. no. 3600020

Maßstab 1:20

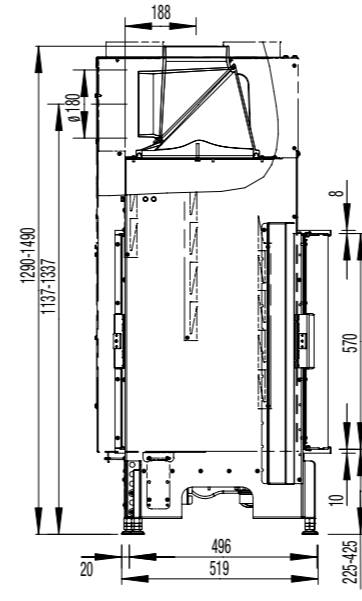
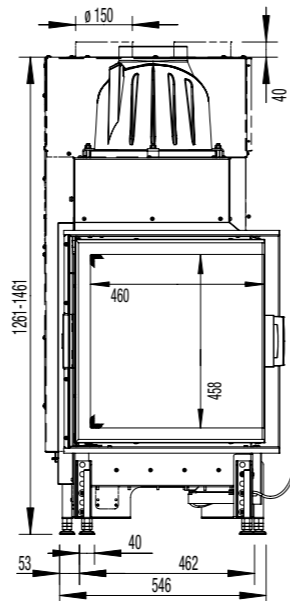

Maßstab 1:10

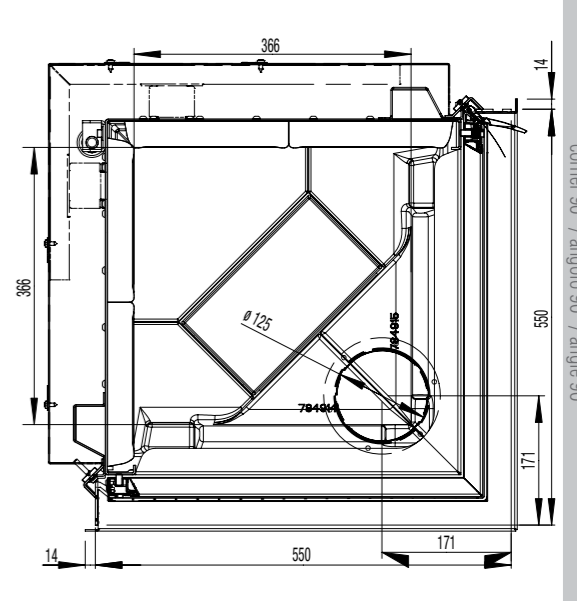
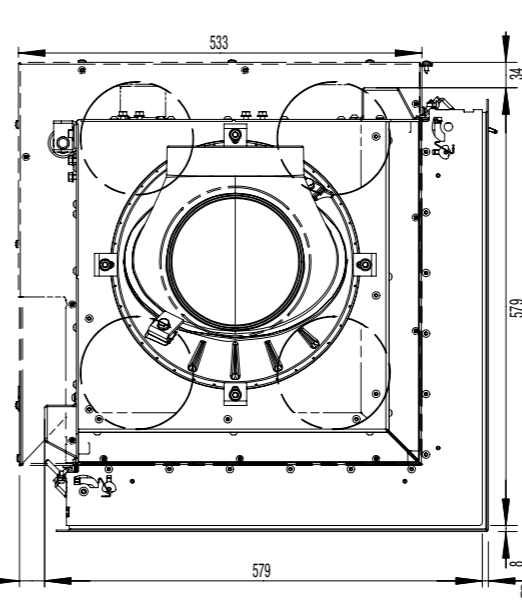

570 Ecke 90°
corner 90° / angolo 90° / angle 90°



Art. no. 3600021

Maßstab 1:20

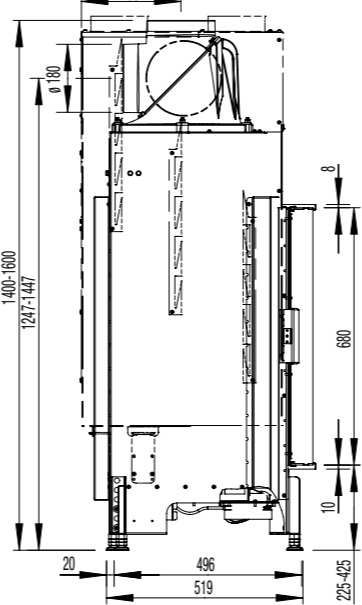
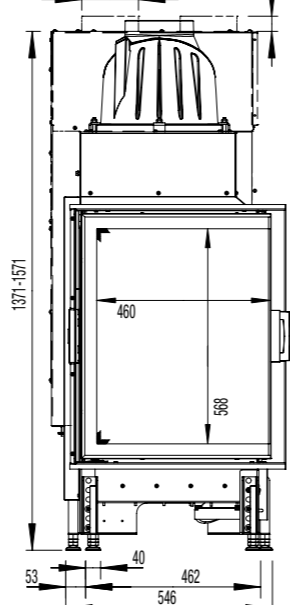

Maßstab 1:10

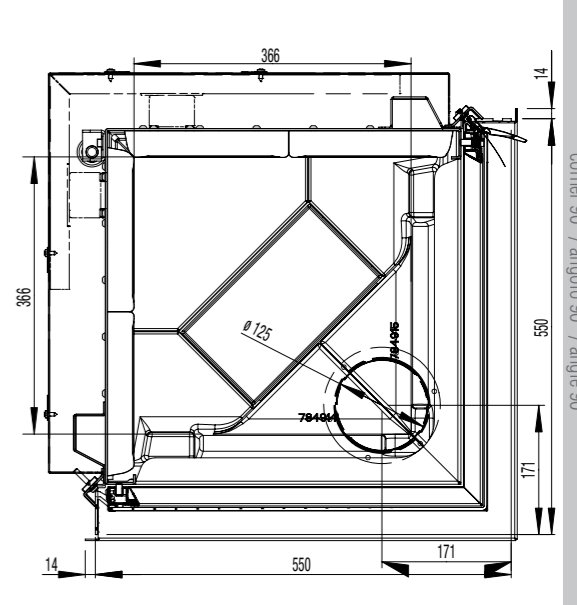
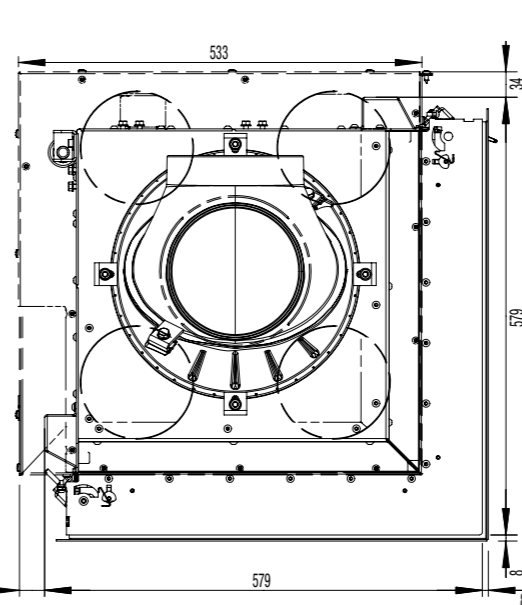

680 Ecke 90°
corner 90° / angolo 90° / angle 90°