

Extrablame®

Riscaldamento a Pellet

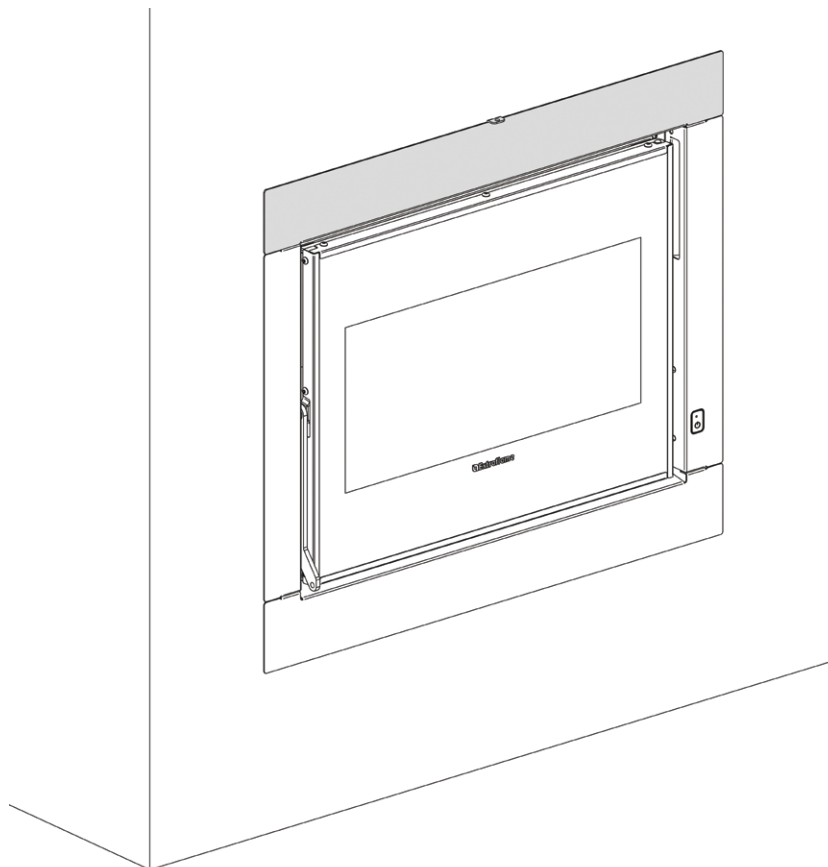

IT

UK

FR

DE

ES

MANUALE ISTRUZIONI CASSETTO FRONTALE INSERTI

INSTRUCTIONS MANUAL FOR FRONT DRAWER INSERTS

MANUEL D'INSTRUCTION DES PIÈCES ENCASTRABLES DU TIROIR FRONTAL

BEDIENUNGSANLEITUNG VORDERE SCHUBLADE EINSATZSTÜCKE

MANUAL DE INSTRUCCION CAJÓN FRONTAL INSERCIONES

COMFORT P70 AIR H49
COMFORT P70 AIR H49 5.0

MADE IN ITALY
design & production

ITALIANO	4
KIT OPZIONALE CARICAMENTO PELLET FRONTALE.....	4
COMPONENTI DEL KIT	5
UTILIZZO DEL CASSETTO	8
SMALTIMENTO	11
ENGLISH	12
OPTIONAL FRONT PELLET LOADING KIT	12
COMPONENTS OF THE KIT	13
HOW TO USE THE TRAY	16
DISPOSAL.....	19
FRANÇAIS	20
KIT OPTIONNEL POUR LE CHARGEMENT FRONTAL DES GRANULÉS.....	20
COMPOSANTS DU KIT	21
UTILISATION DU TIROIR	24
ÉLIMINATION.....	27
DEUTSCH.....	28
OPTIONALES KIT ZUM FRONTALEN LADEN DER PELLETS	28
KOMPONENTEN DES KIT	29
GEBRAUCH DER SCHUBLADE	32
BESEITIGUNG	35
ESPAÑOL	36
KIT OPCIONAL CARGA PELLET FRONTAL.....	36
COMPONENTES DEL KIT	37
UTILIZACIÓN DEL CAJÓN.....	40
ELIMINACIÓN	43

KIT OPZIONALE CARICAMENTO PELLETT FRONTALE

Il kit opzionale di caricamento pellet consente di caricare frontalmente il pellet all'interno del serbatoio senza dover procedere con l'estrazione dell'insero (operazione che richiede lo spegnimento della macchina).

Prima di procedere con l'installazione dell'apparecchio è necessario assicurarsi che la struttura che rivestirà l'insero garantisca un foro con le misure minime indicate nella figure sotto.

Nell'immagini sono riportate le misure minime da rispettare tra l'insero e il rivestimento: tali misure risultano necessarie per permettere il corretto movimento della cornice e la sua rimozione dalla locazione originaria.

Il montaggio è possibile anche da inserto montato.

COMFORT P70 AIR H49 - COMFORT P70 AIR H49 5.0

550 X 700 MM CON CASSETTO OPTIONAL

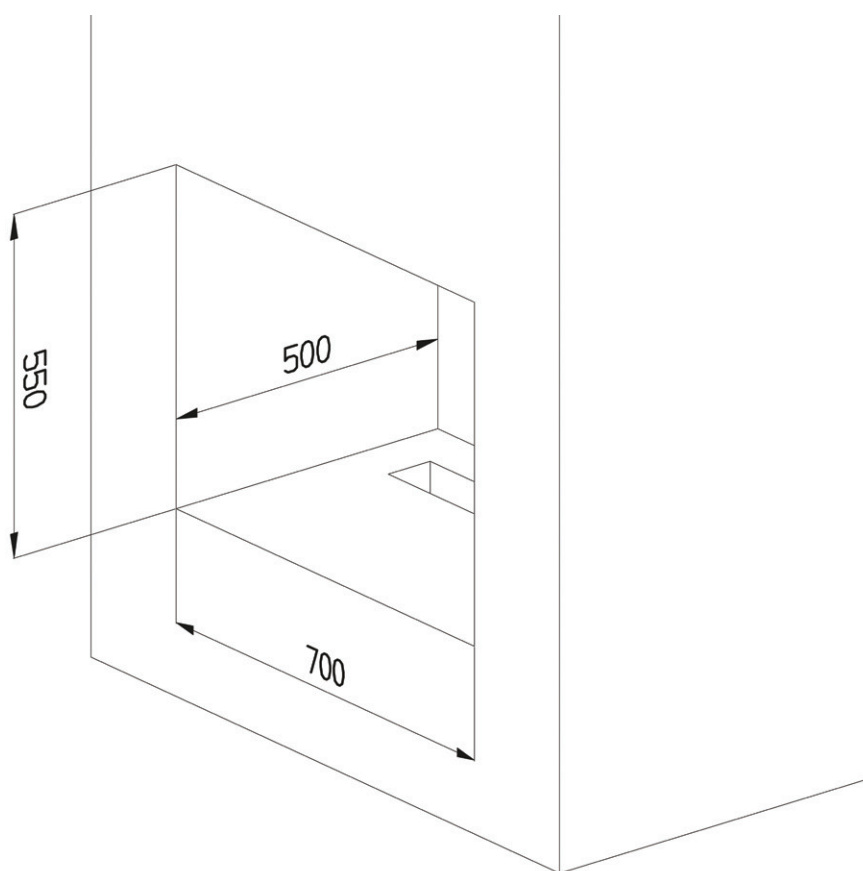

ATTENZIONE:

**ESEGUIRE LE INDICAZIONI SEMPRE NELLA MASSIMA SICUREZZA!
LA STUFA DEVE ESSERE COMPLETAMENTE FREDDA, SPENTA
E SCOLLEGATA LA PRESA ELETTRICA DI RETE.**

**PER UN CORRETTO FUNZIONAMENTO DELL'INSERTO, IL CASSETTO DEVE RIMANERE SEMPRE
CHIUSO TRANNE DURANTE LA FASE DI CARICO SERBATOIO.**

**SI RACCOMANDA DI NON CARICARE UNA QUANTITÀ DI PELLETT SUPERIORE ALLA CAPACITÀ
DEL SERBATOIO, ED EVITARE DI FAR CADERE DEL PELLETT ALL'INTERNO DEL PRODOTTO**

COMPONENTI DEL KIT

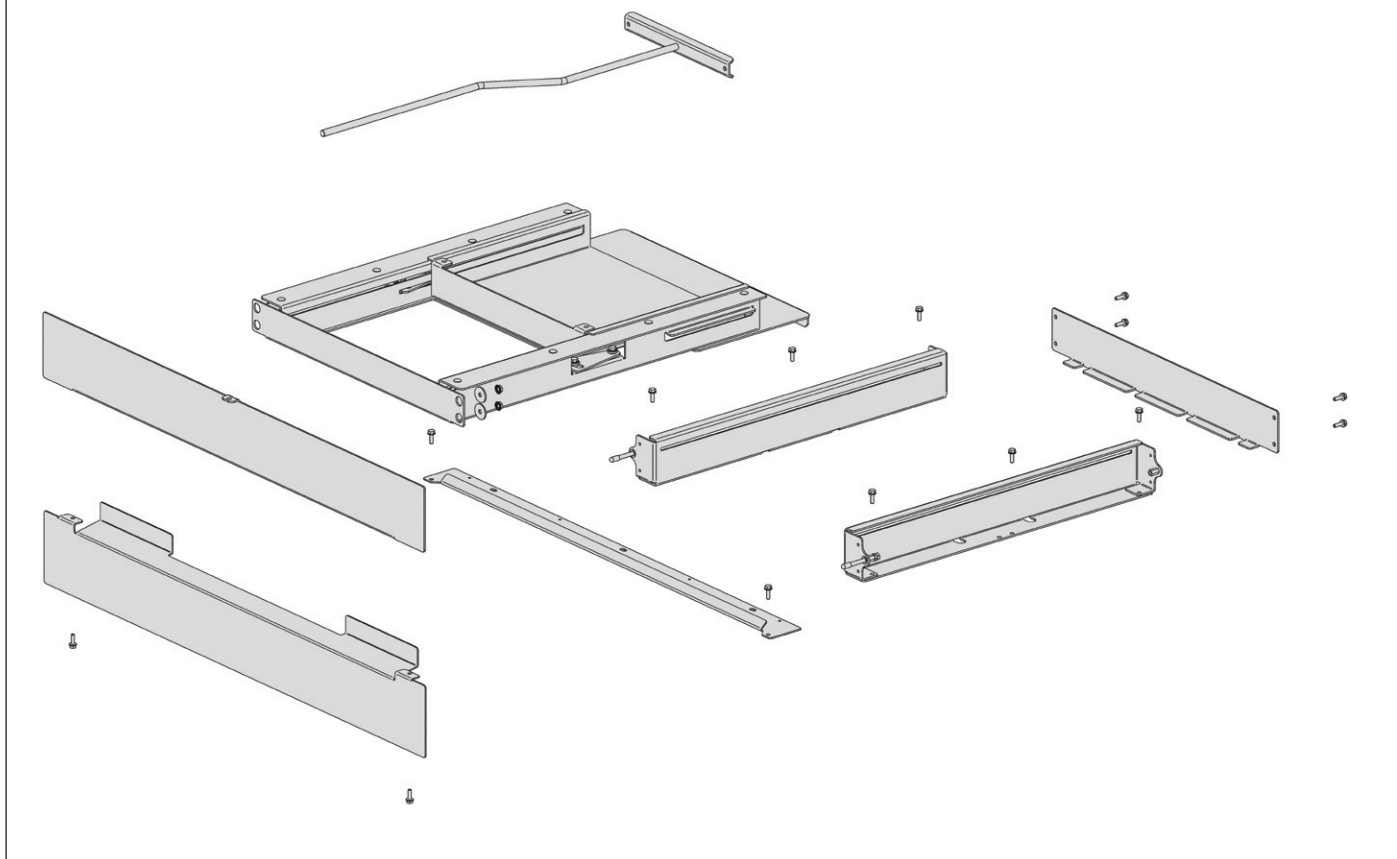

1 Rimuovere la cornice frontale

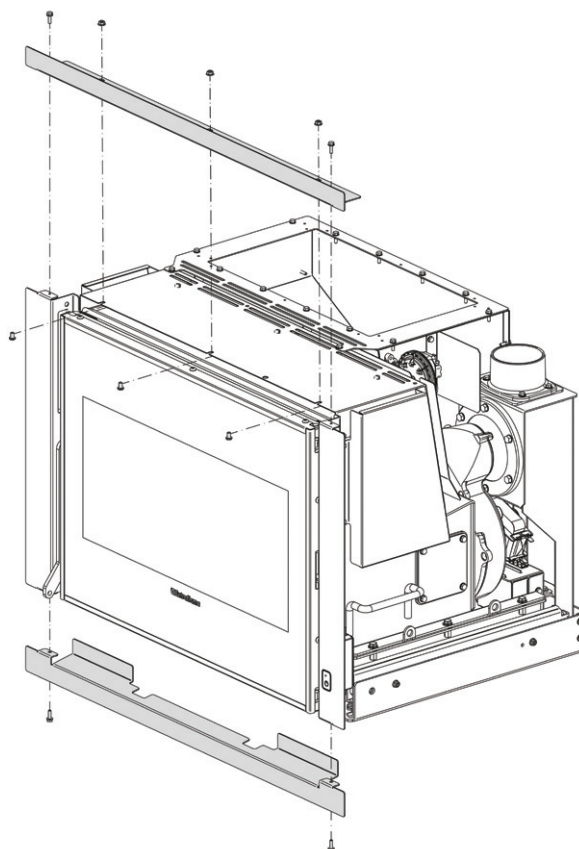

2 Installare le cornici in dotazione al kit

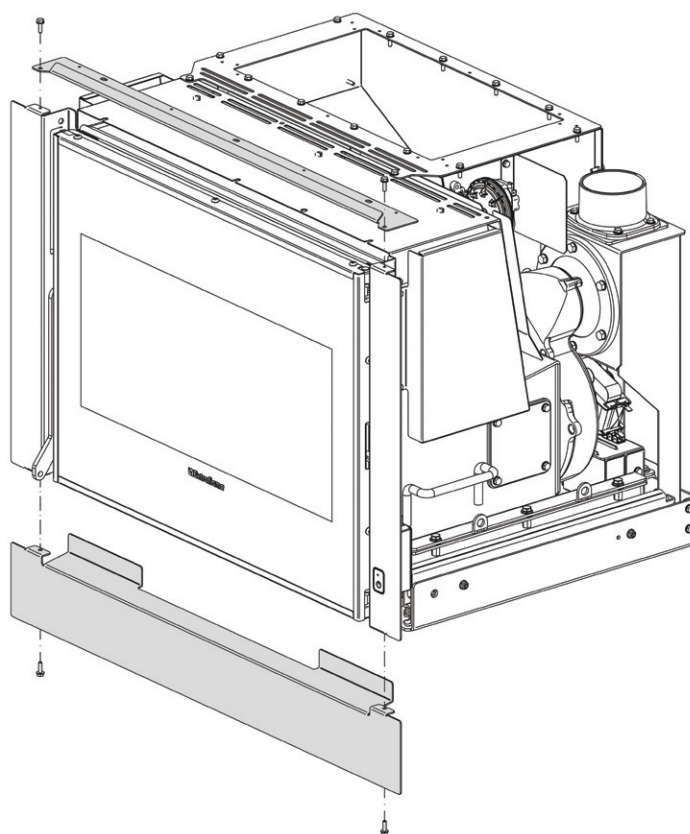

3 Fissare rotaia destra

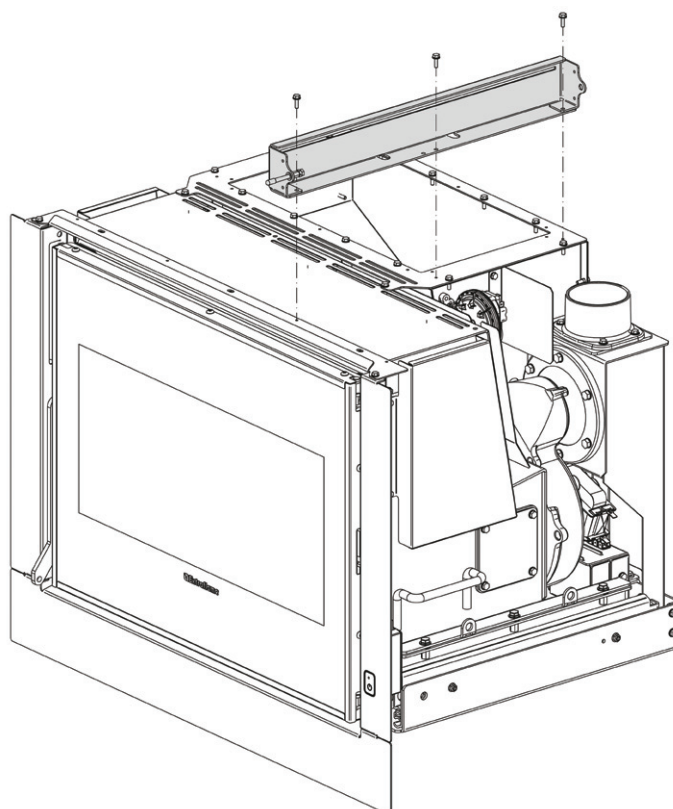

4 Inserire il cassetto e la rotaia sinistra.

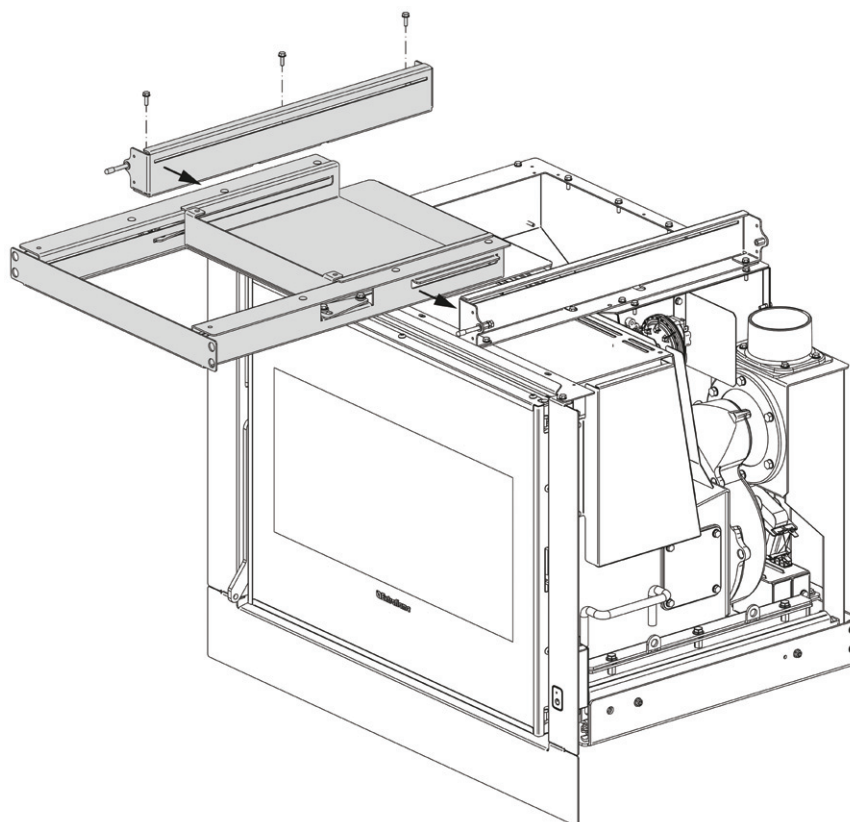

5 Fissare rotaia sinistra e rinforzo posteriore.

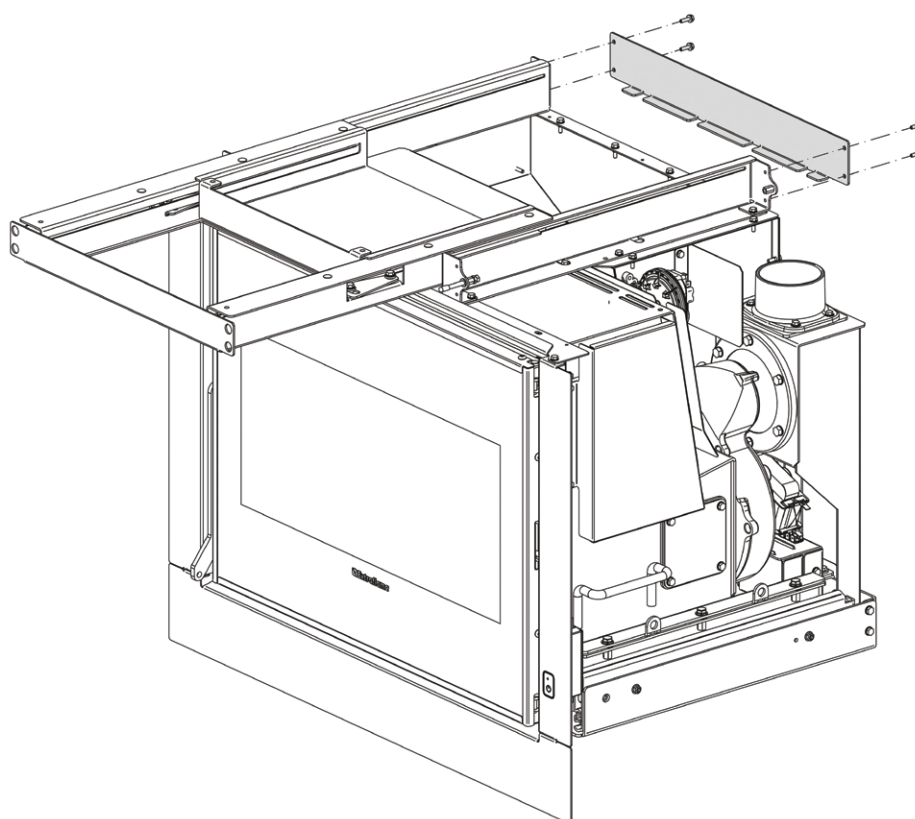

6 Fissare la cornice estetica.

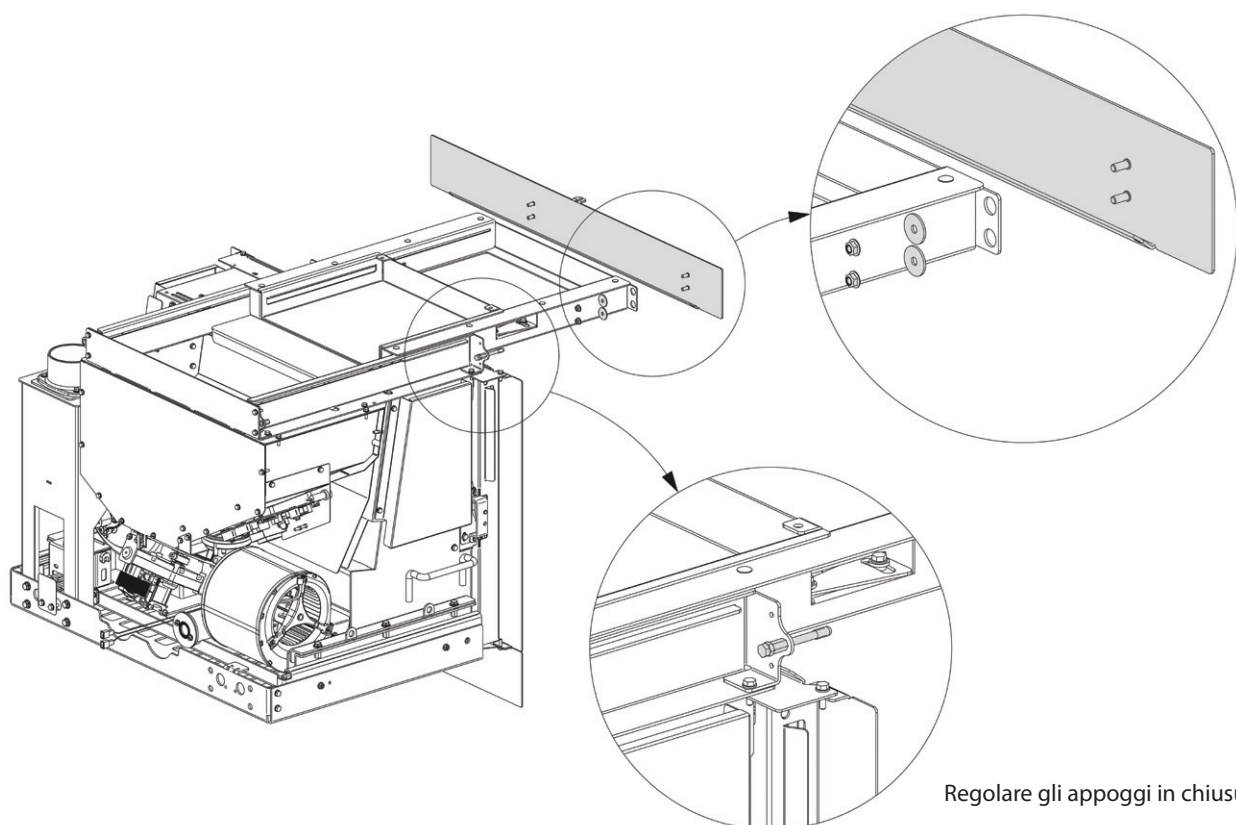

UTILIZZO DEL CASSETTO

A Estrarre il cassetto (A) fino alla massima estensione, mediante l'uso dell'attizzatoio in dotazione.

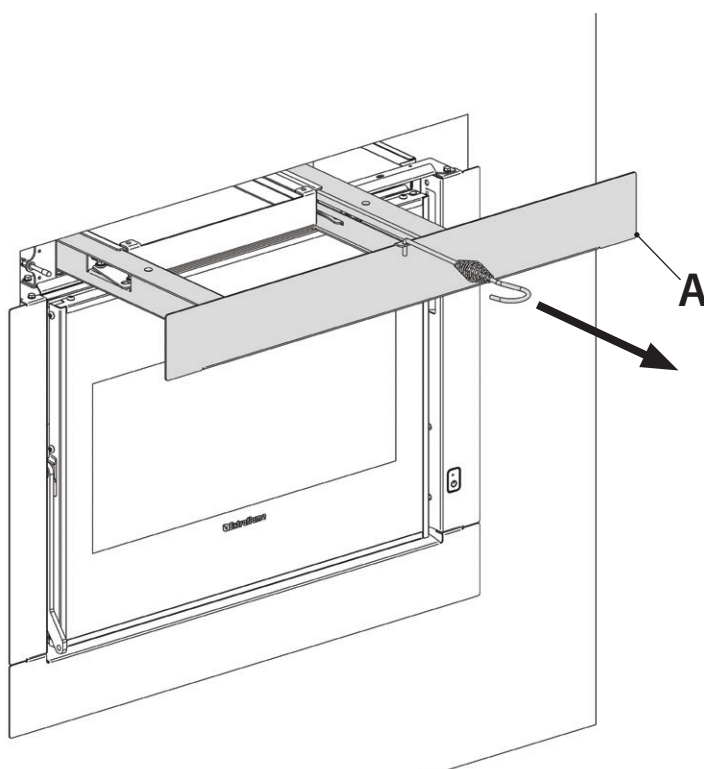

B

Estrarre il cassetto (B) fino alla massima estensione, mediante l'uso dell'attizzatoio in dotazione.

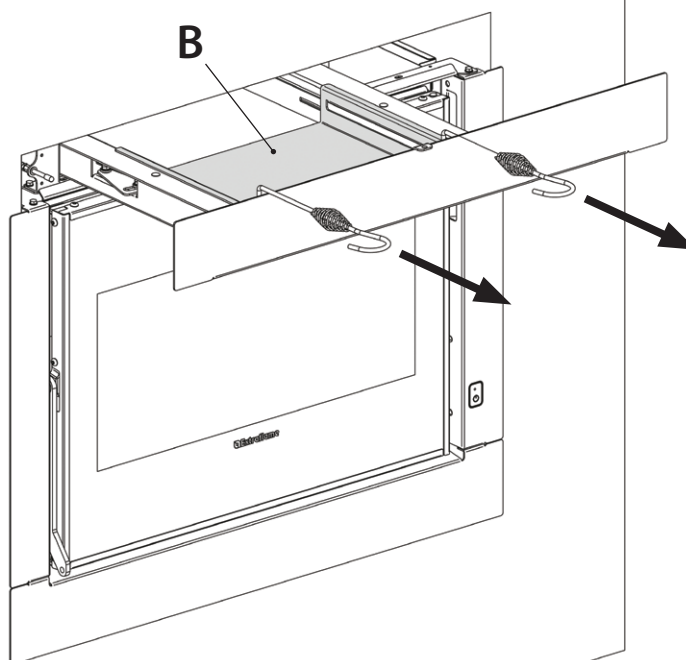

C

Caricare il pellet sul cassetto e utilizzare il raschietto in dotazione per spingerlo nel serbatoio retrostante.
E' tassativo svuotare totalmente il pellet dal cassetto al serbatoio retrostante!

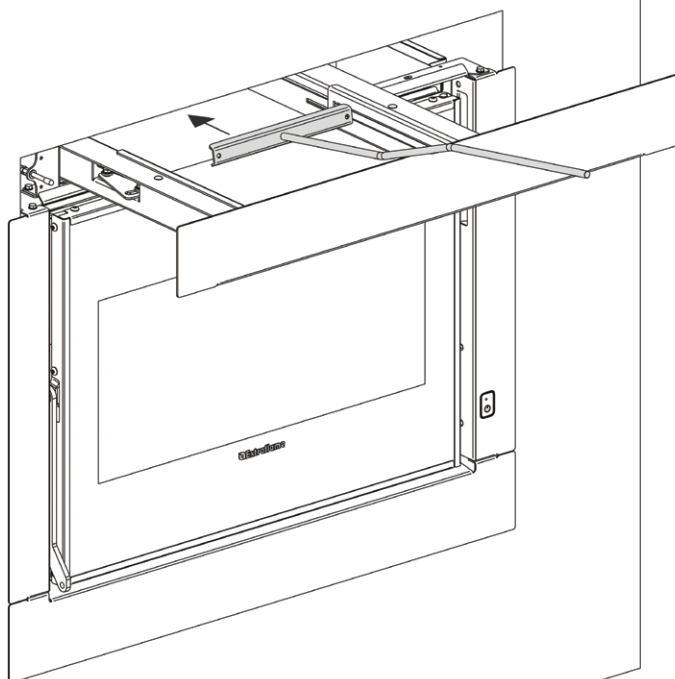

D

A caricamento pellet ultimato, chiudere il cassetto (B) mediante l'uso degli attizzatoi in dotazione.

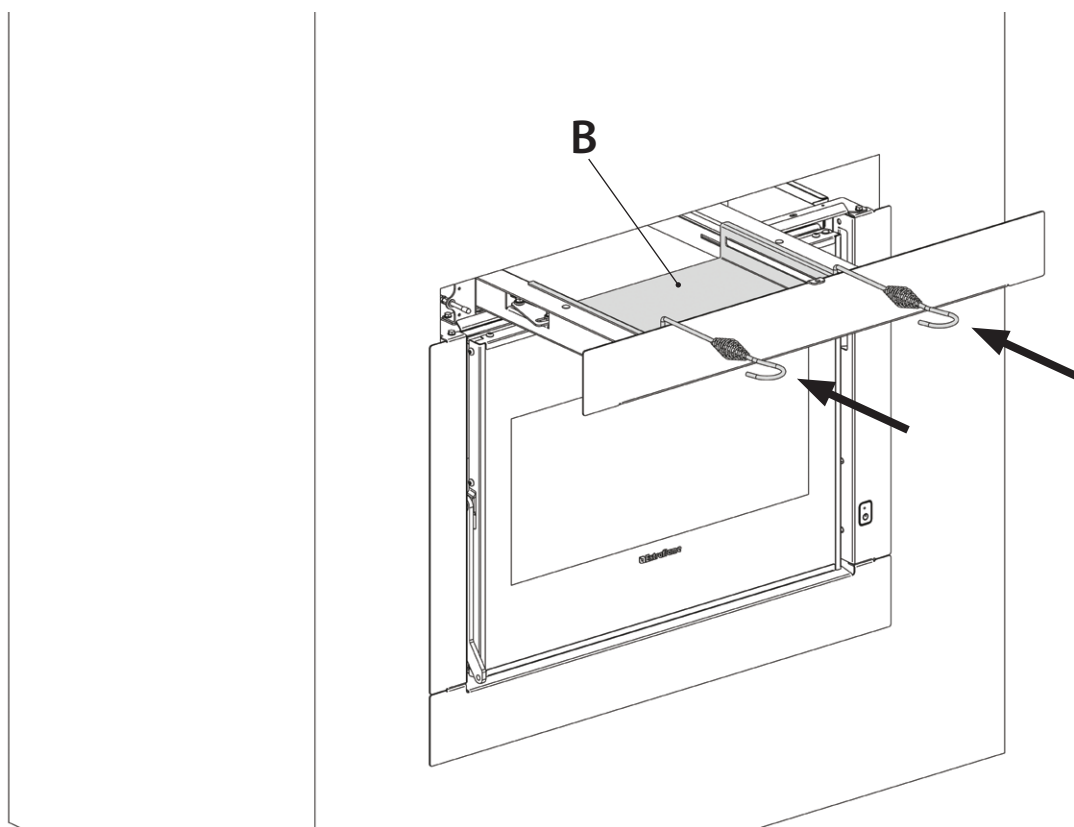
**E**

Una volta chiuso il cassetto (B), sarà possibile chiudere il cassetto (A) mediante l'uso dell'attizzatoio in dotazione.

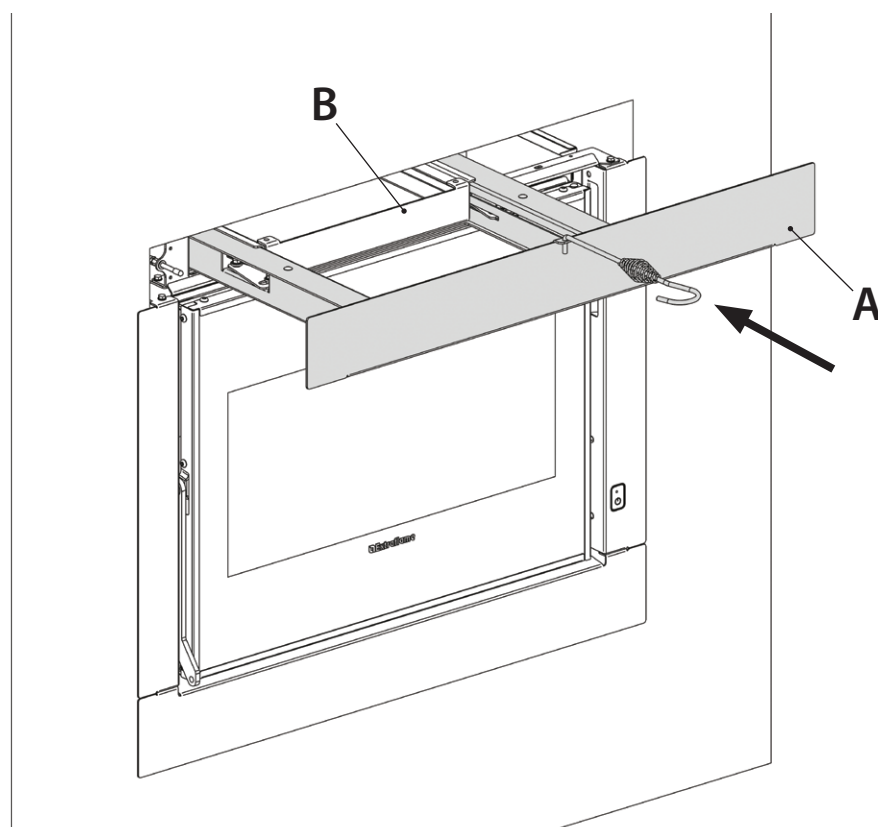

F Per un corretto funzionamento del camino, il cassetto di caricamento deve essere estratto solamente per il tempo necessario al caricamento del serbatoio. Poi deve restare chiuso come da immagine allegata.

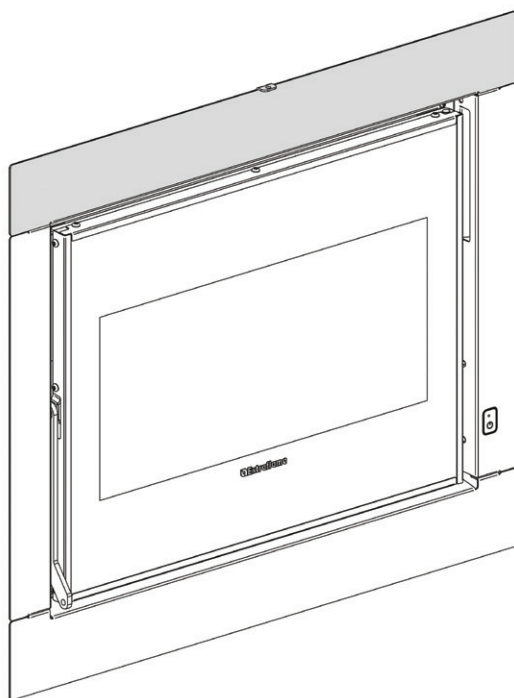

SMALTIMENTO

AL MOMENTO DELLO SMALTIMENTO, QUESTO ACCESSORIO DEVE ESSERE SEPARATO DAL PRODOTTO PRINCIPALE SU CUI ERA ORIGINARIAMENTE INCLUSO, E DEVE ESSERE SMALTITO SEPARATAMENTE SECONDO LE NORMATIVE NAZIONALI RELATIVE ALLA SUA TIPOLOGIA DI MATERIALE.

OPTIONAL FRONT PELLET LOADING KIT

The optional front pellet loading kit allows for the pellets to be loaded into the tank from the front without having to remove the insert (operation that requires switching off the machine).

Before installing the equipment, it is necessary to make sure that the structure that will cover the insert ensures a hole with the minimum measurements indicated in the figures below.

The pictures show the minimum measurements between the insert and the cover: these measurements are necessary to allow for the frame to move correctly and to be removed from its original position.

Assembly is possible even with the insert installed.

COMFORT P70 AIR H49 - COMFORT P70 AIR H49 5.0

550 X 700 MM WITH OPTIONAL TRAY

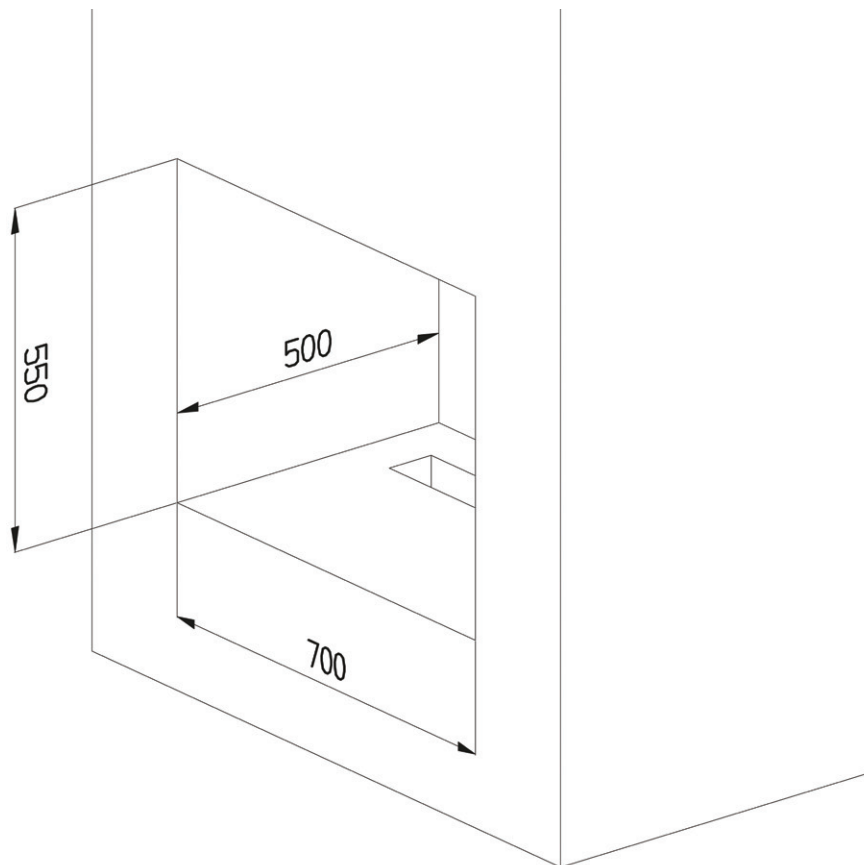

WARNING:

**ALWAYS FOLLOW THE INSTRUCTIONS IN COMPLETE SAFETY!
THE STOVE MUST BE COMPLETELY COLD, SWITCHED OFF
AND DISCONNECTED FROM THE ELECTRICAL OUTLET.**

**FOR THE CORRECT OPERATION OF THE INSERT, THE TRAY MUST ALWAYS REMAIN
CLOSED EXCEPT FOR WHEN THE TANK IS BEING LOADED.**

**WE RECOMMEND NOT LOADING AN AMOUNT OF PELLETS GREATER THAN THE CAPACITY
OF THE TANK, AND AVOID DROPPING PELLETS INSIDE THE PRODUCT**

COMPONENTS OF THE KIT

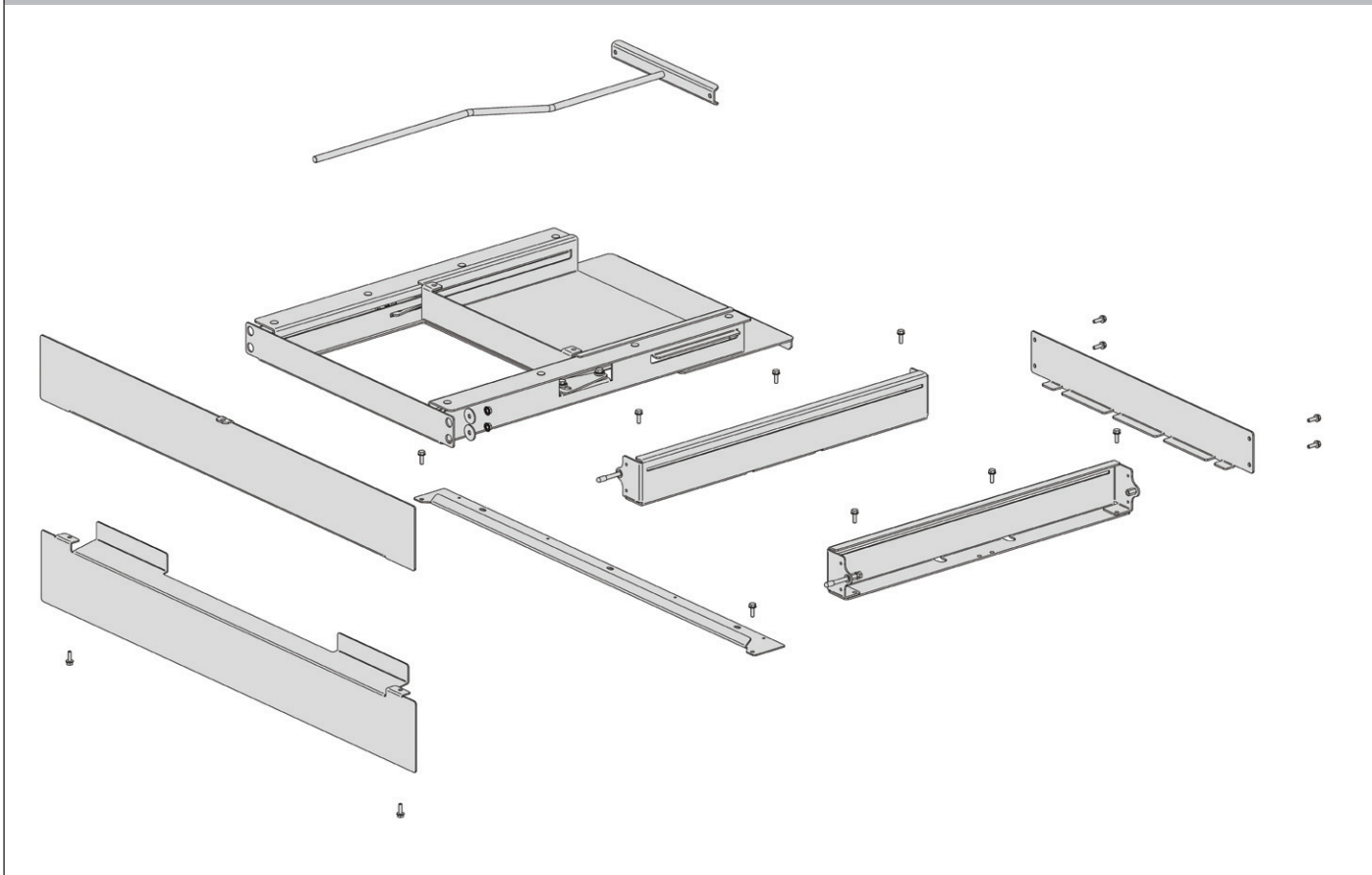

1 Remove the front frame

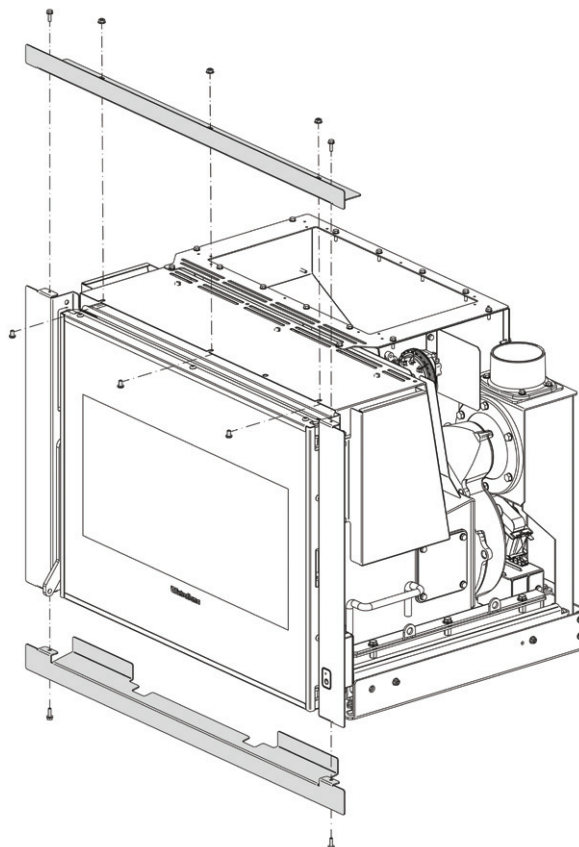

2 Install the frames supplied with the kit

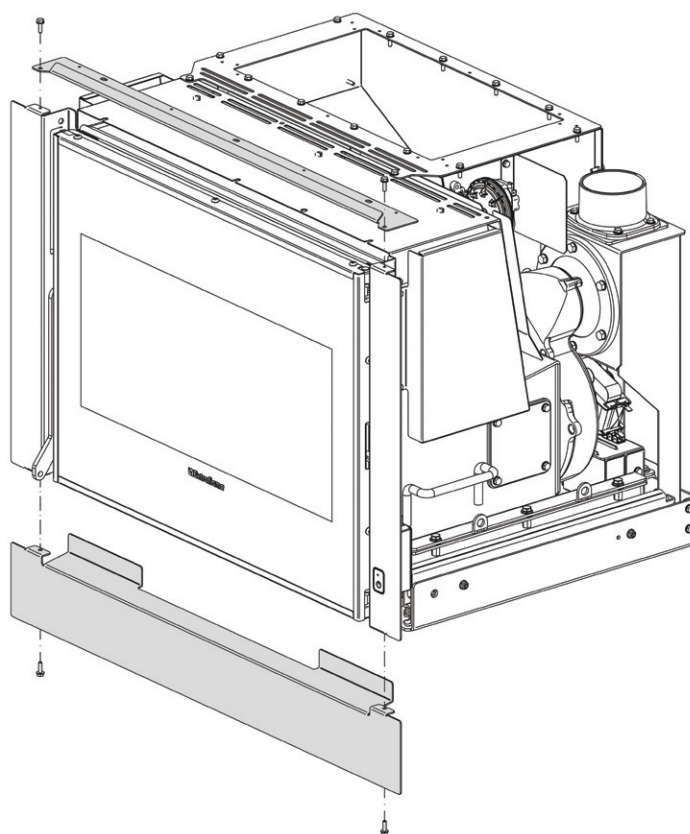

3 Tighten the right rail

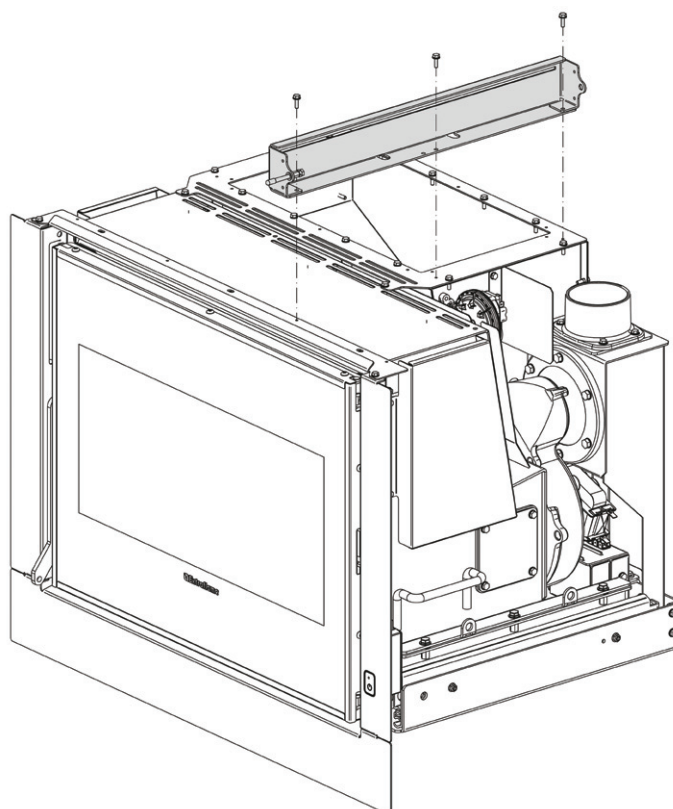

4 Insert the drawer and the left rail

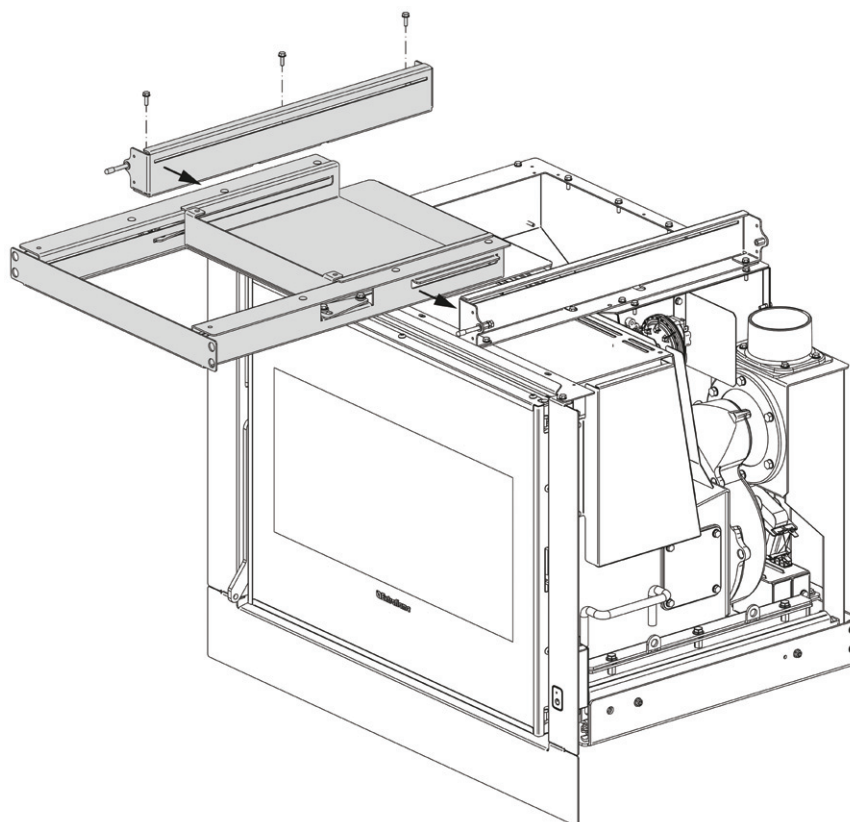

5 Tighten the left rail and back plate

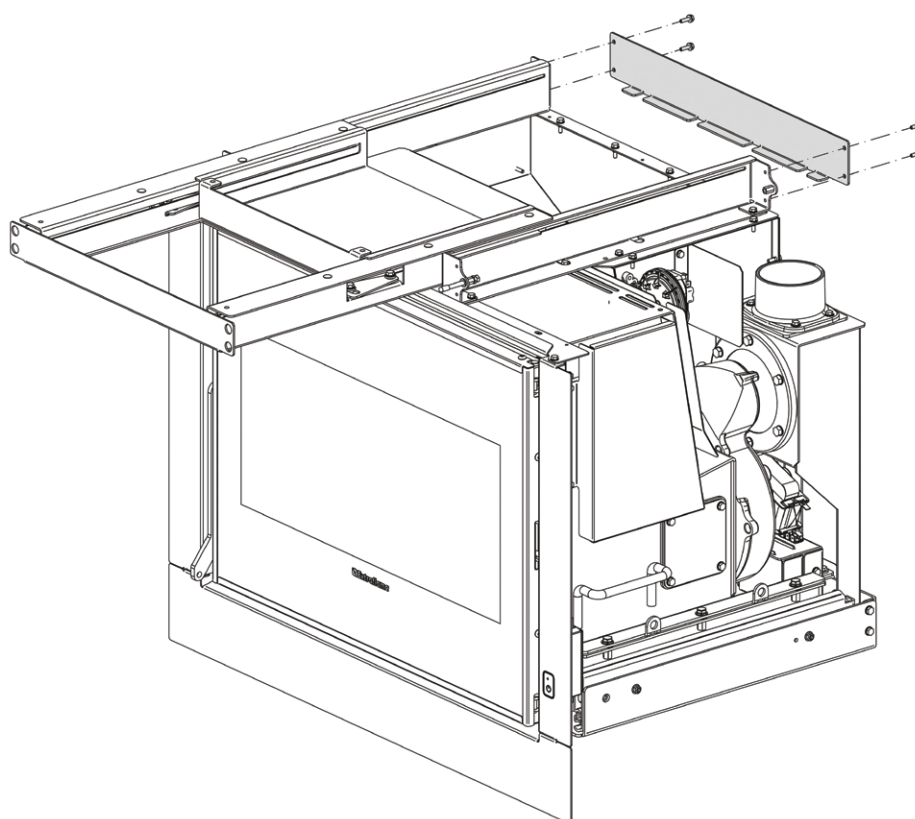

6 Tighten the aesthetic frame

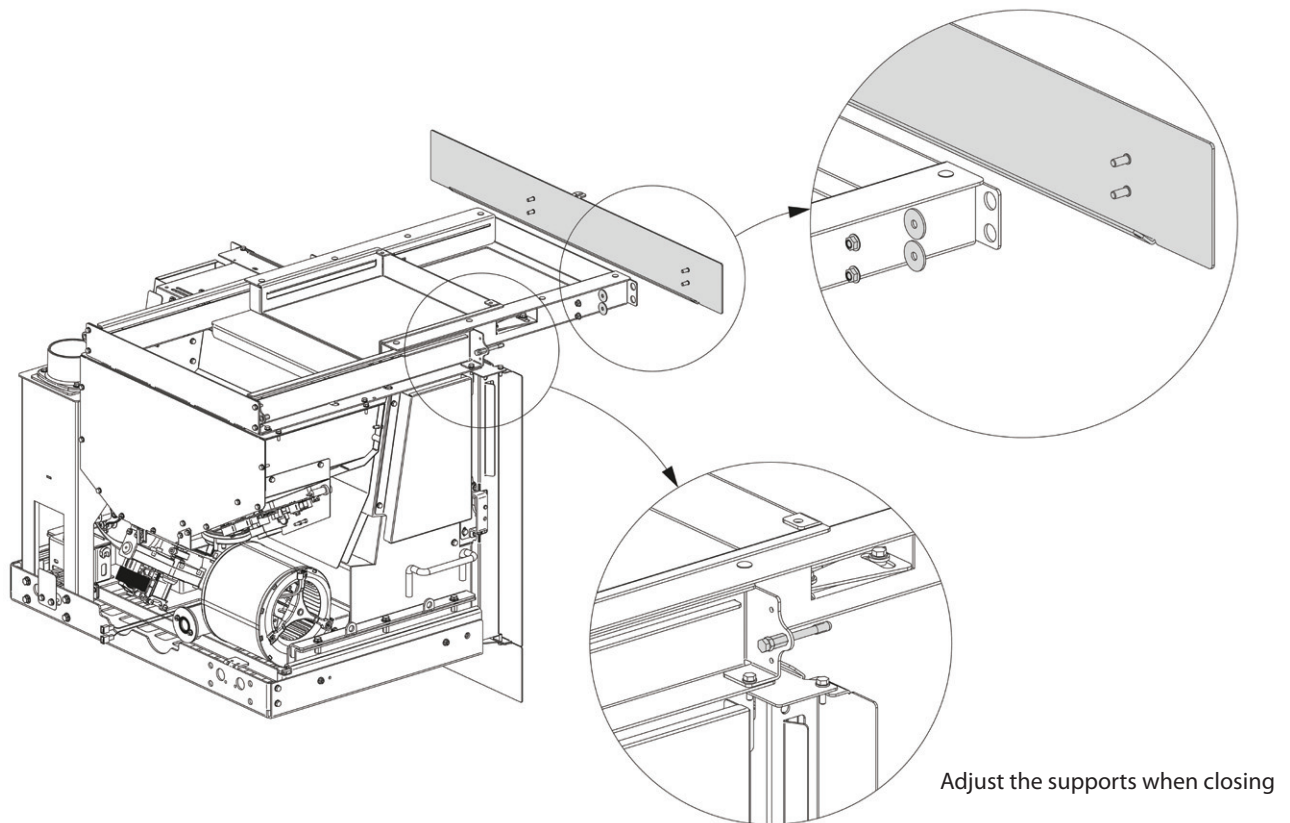

HOW TO USE THE TRAY

A Extract the drawer (A) until the maximum extension with the supplied poker

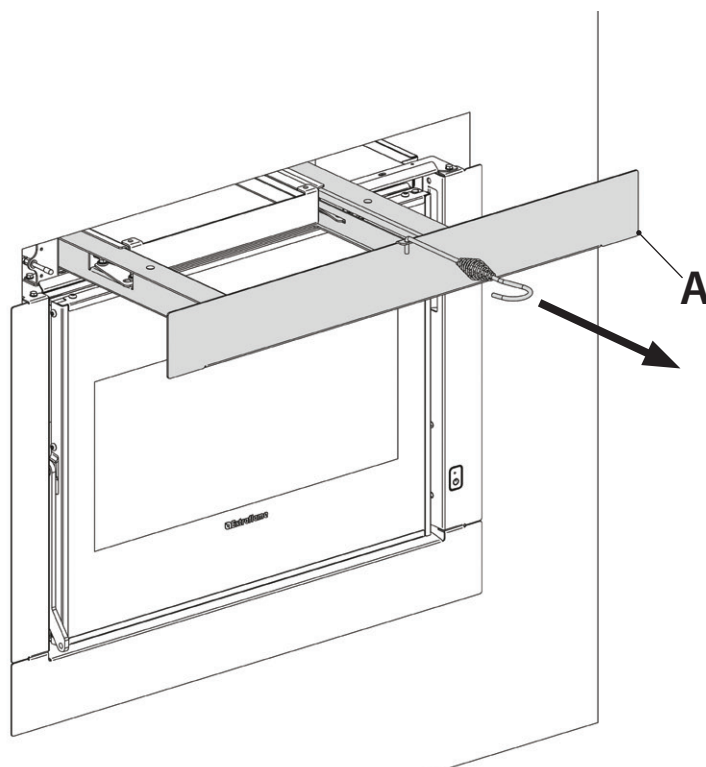

- B** Extract the drawer (B) until the maximum extension with the supplied poker

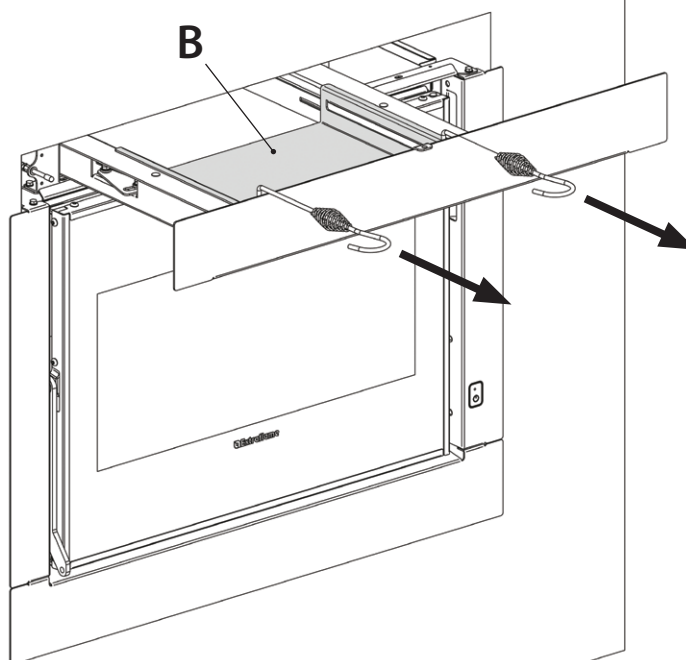

- C** Load the pellet into the drawer and use the supplied scraper to push it in the back hopper.
Is mandatory to empty completely the pellet from the drawer to the hopper!

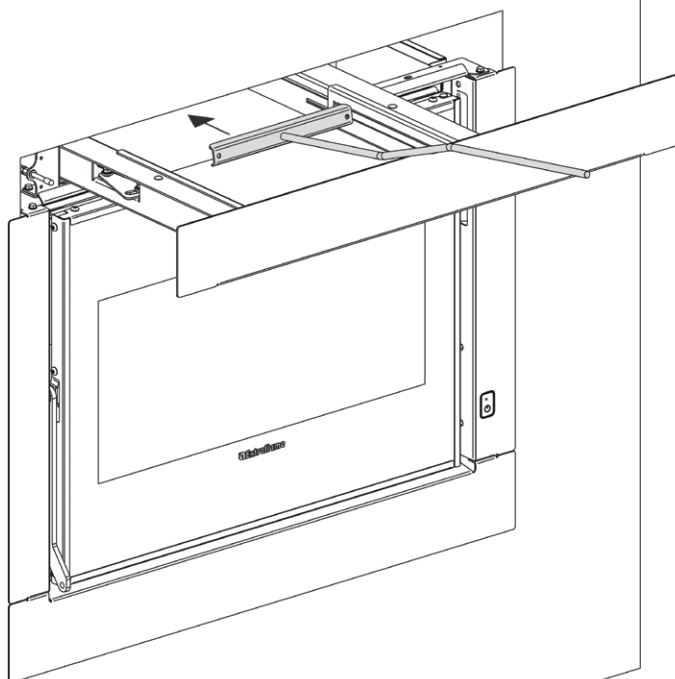

D When the load is finished, close the drawer (B) with the supplied pokers.

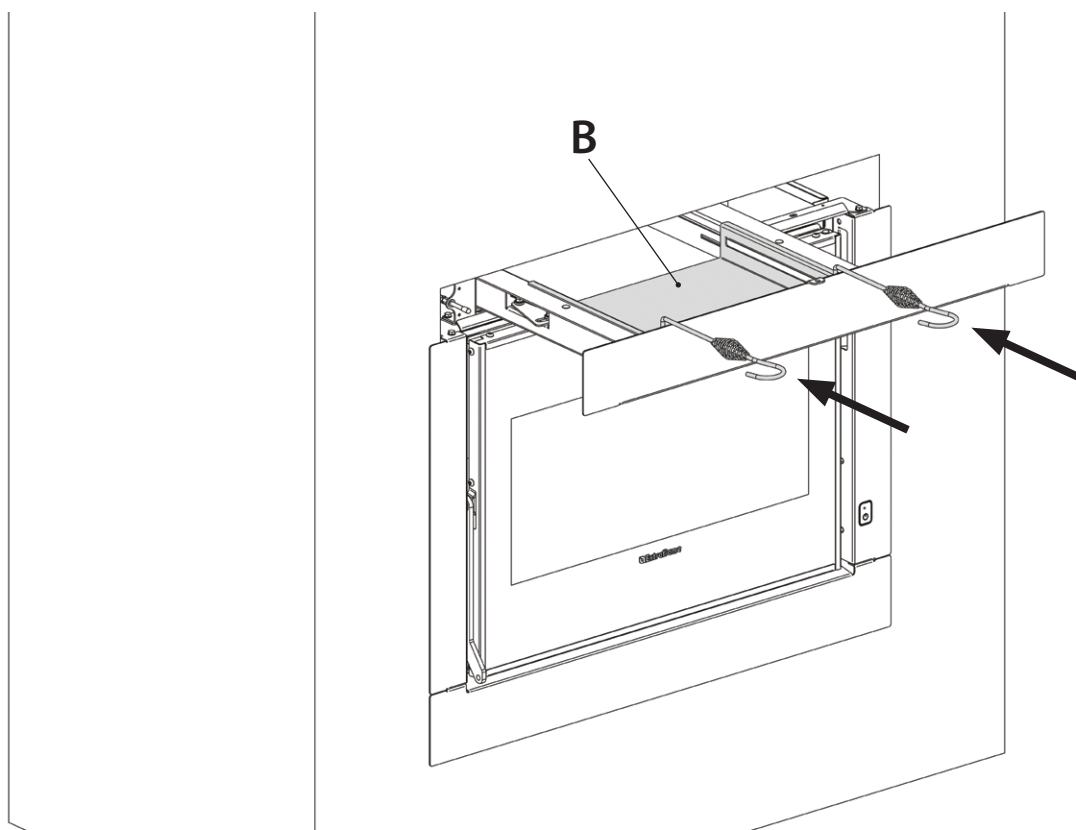

E Once the drawer is closed (B), it will be possible to close the drawer (A) with the supplied pokers

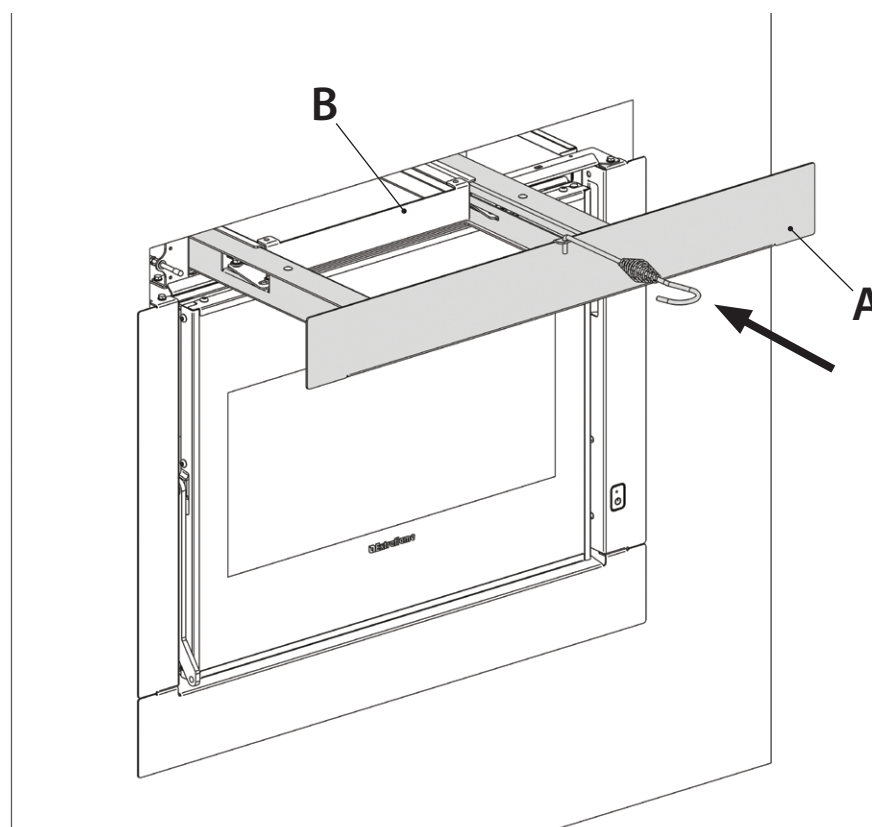

F For a correct use of the chimney, the drawer have to be extracted only for the time necessary to load the hopper. It has to remain closed as the following image.

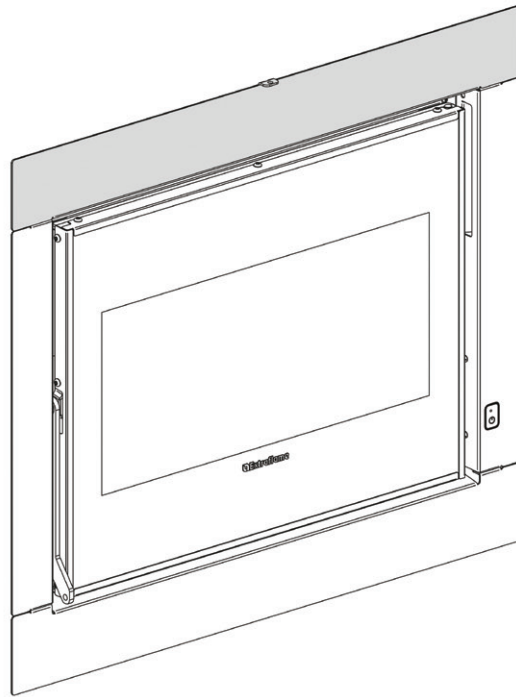

DISPOSAL

WHEN DISPOSING, THIS ACCESSORY MUST BE SEPARATED FROM THE MAIN PRODUCT ON WHICH IT WAS ORIGINALLY INCLUDED, AND SHOULD BE DISPOSED SEPARATELY IN ACCORDANCE TO THE NATIONAL REGULATIONS RELATING TO ITS TYPE OF MATERIAL.

KIT OPTIONNEL POUR LE CHARGEMENT FRONTAL DES GRANULÉS

Le kit optionnel de chargement granulés permet de charger de front les granulés à l'intérieur du réservoir sans devoir extraire l'insert (opération qui requiert l'arrêt de la machine).

Avant d'installer l'appareil il faut s'assurer que la structure qui revêtira l'insert prévoise un orifice avec les mesures minimales indiquées sur la figure ci-dessous.

L'image reporte les mesures minimales à respecter entre l'insert et le revêtement : ces mesures s'avèrent nécessaires pour permettre le mouvement correct du cadre et son retrait de l'emplacement d'origine.

Le montage est possible également avec l'insert monté.

COMFORT P70 AIR H49 - COMFORT P70 AIR H49 5.0

550 X 700 MM AVEC TIROIR OPTIONNEL

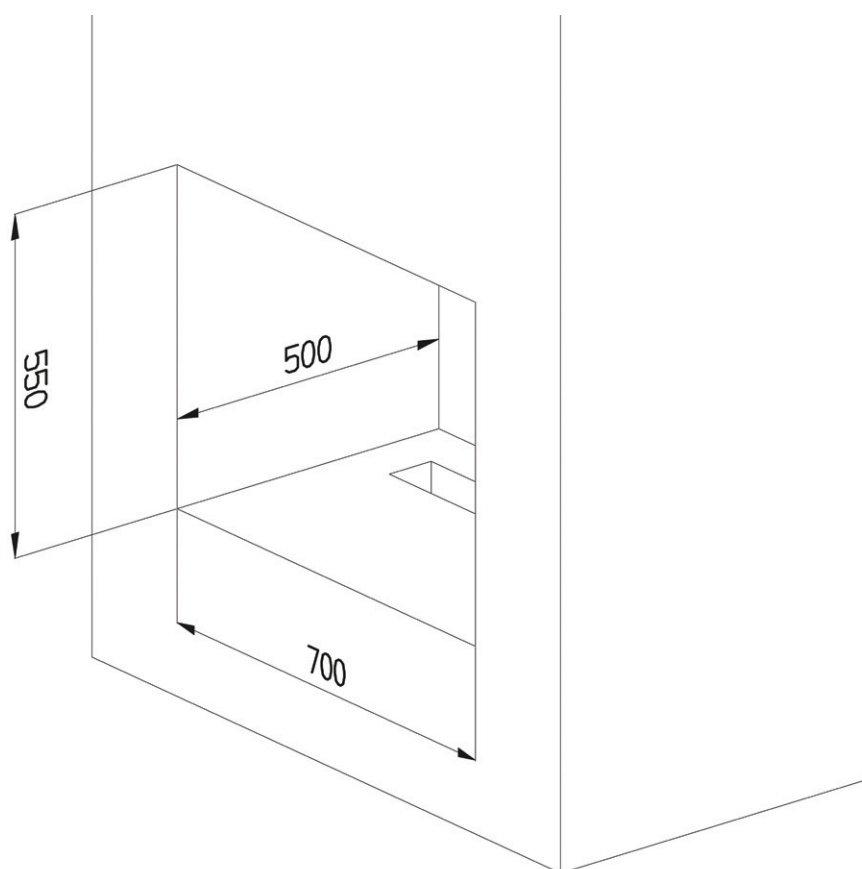

ATTENTION :

**TOUJOURS SUIVRE LES INDICATIONS EN TOUTE SÉCURITÉ !
LE POÊLE DOIT ÊTRE COMPLÈTEMENT FROID, ÉTEINT
ET LA PRISE ÉLECTRIQUE DOIT ÊTRE DÉBRANCHÉE DU SECTEUR.**

**POUR UN FONCTIONNEMENT CORRECT DE L'INSERT, LE TIROIR DOIT TOUJOURS RESTER
FERMÉ SAUF DURANT LA PHASE DE CHARGEMENT DU RÉSERVOIR.**

**ON RECOMMANDE DE NE PAS CHARGER UNE QUANTITÉ DE GRANULÉS SUPÉRIEURE À LA CAPACITÉ
DU RÉSERVOIR, ET D'ÉVITER DE FAIRE TOMBER DES GRANULÉS À L'INTÉRIEUR DU PRODUIT**

COMPOSANTS DU KIT

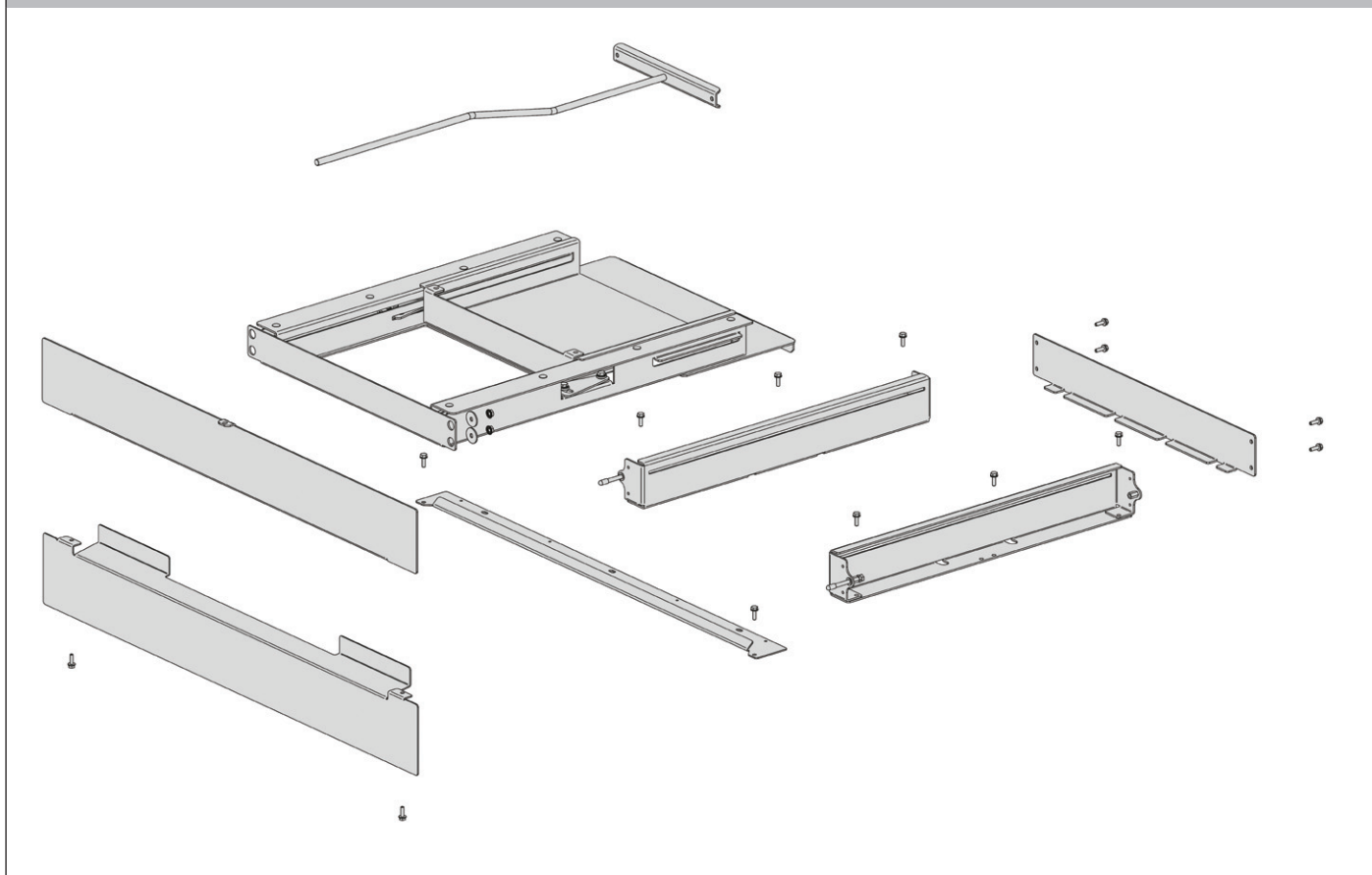

1 Retirez le cadre frontal

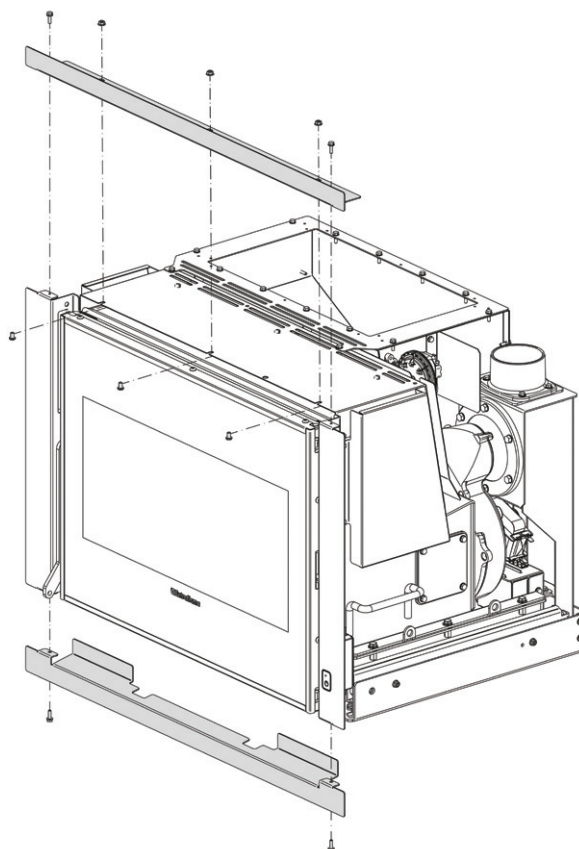

2 Installez les cadres fournis avec le kit

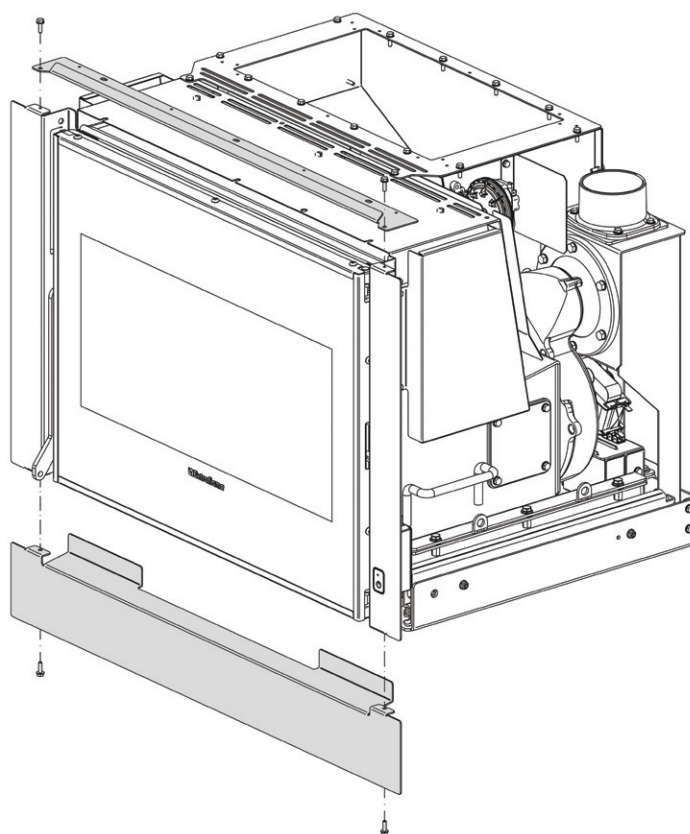

3 Fixer le rail droit

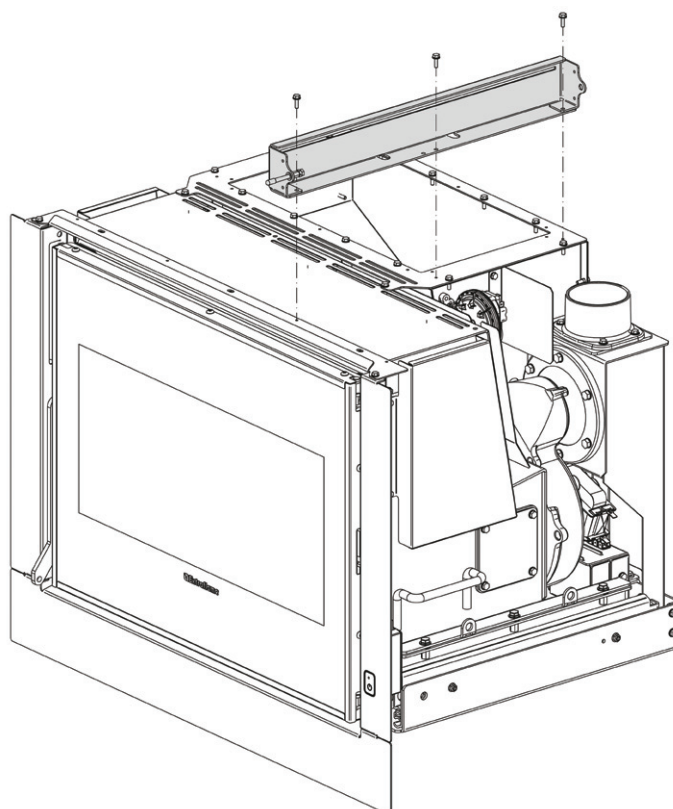

4 Insérez le tiroir et le rail gauche.

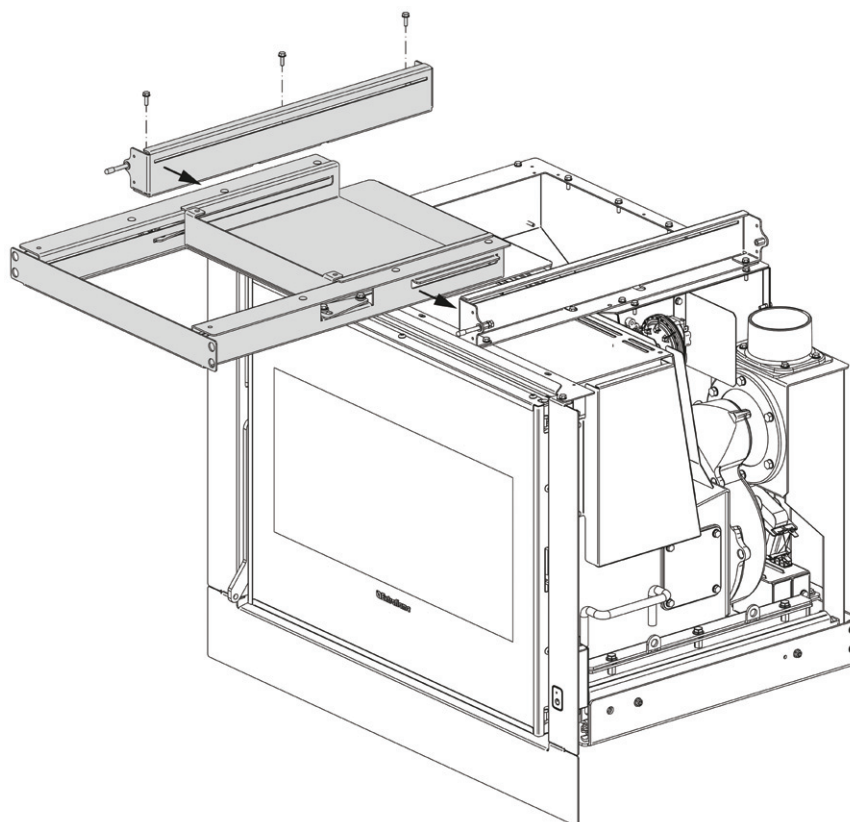

5 Fixez le rail gauche et le renfort posterior.

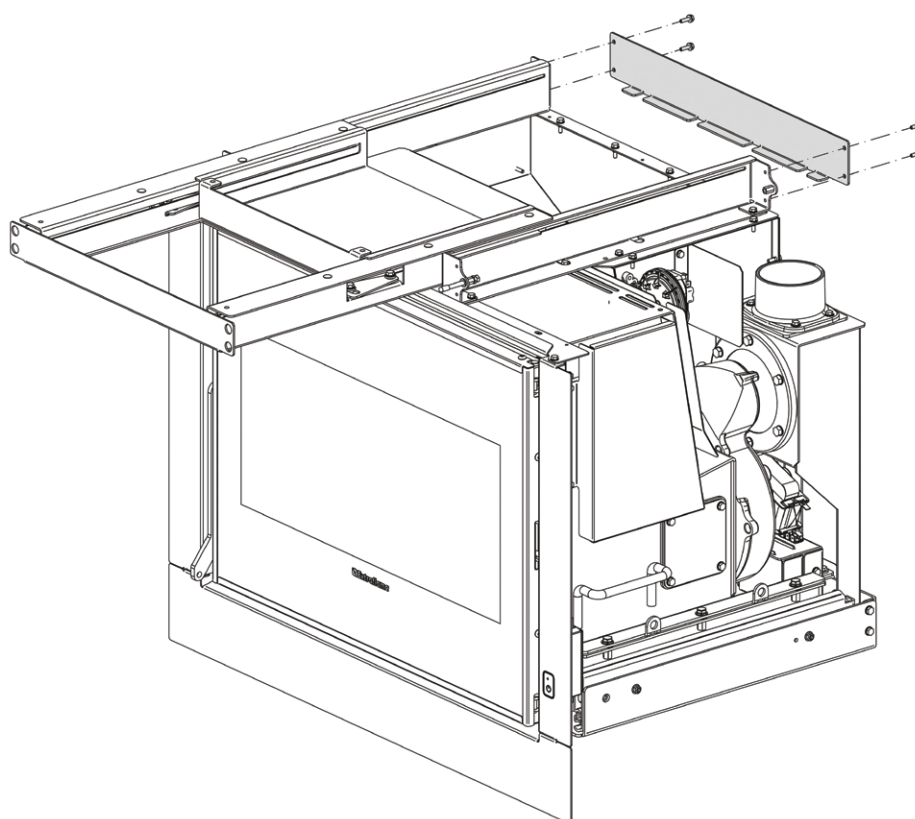

6 Fixez le cadre esthétique.

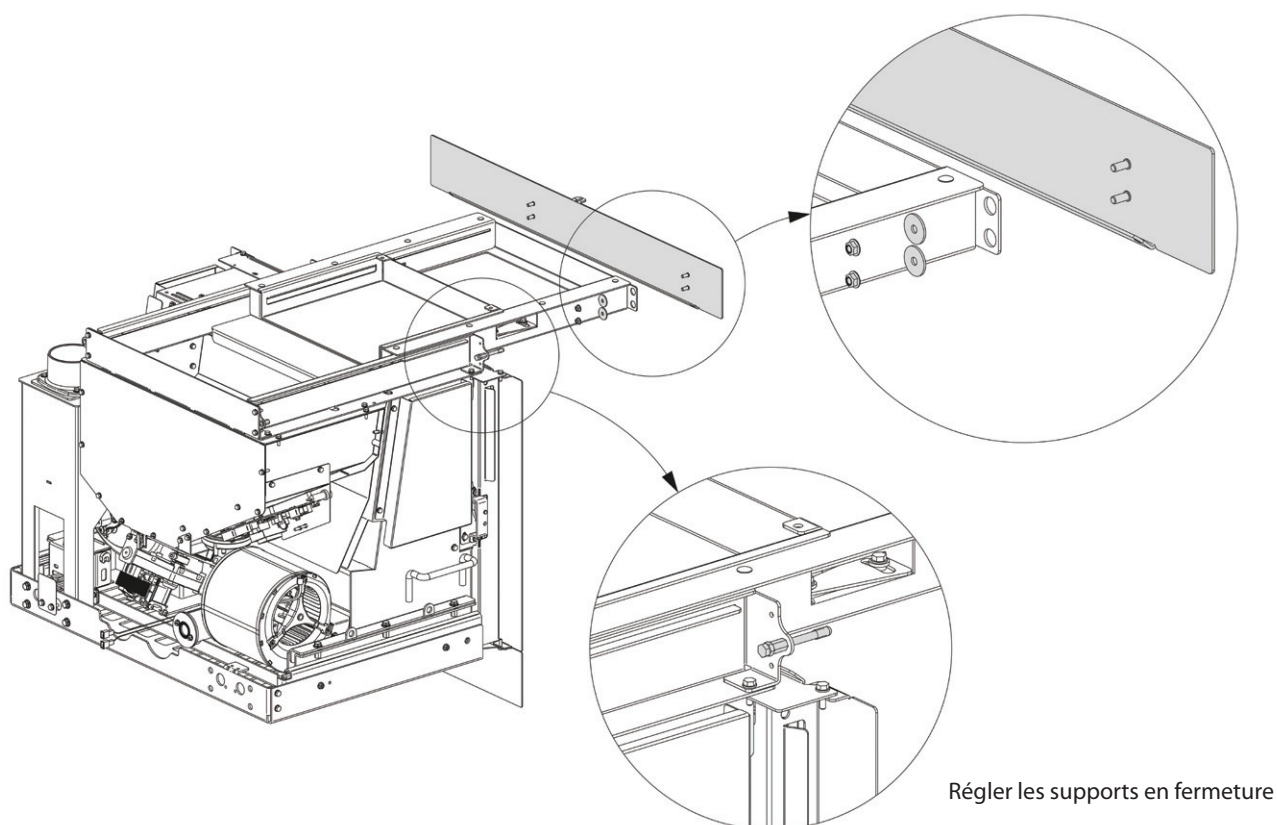

UTILISATION DU TIROIR

A Extraire le tiroir (A) jusqu'à l'extension maximale en utilisant le tisonnier fourni.

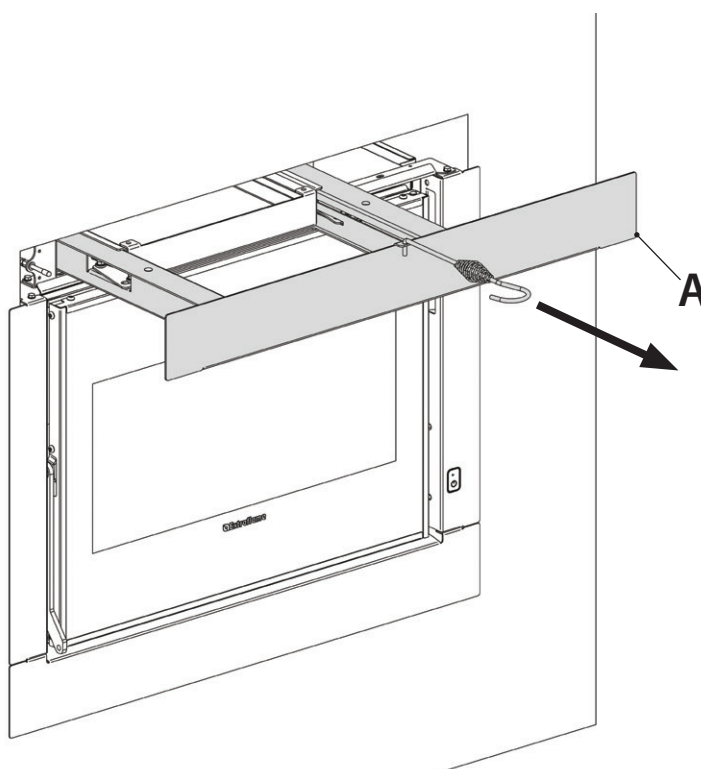

B Extraire le tiroir (B) jusqu'à l'extension maximale à l'aide du tisonnier fourni.

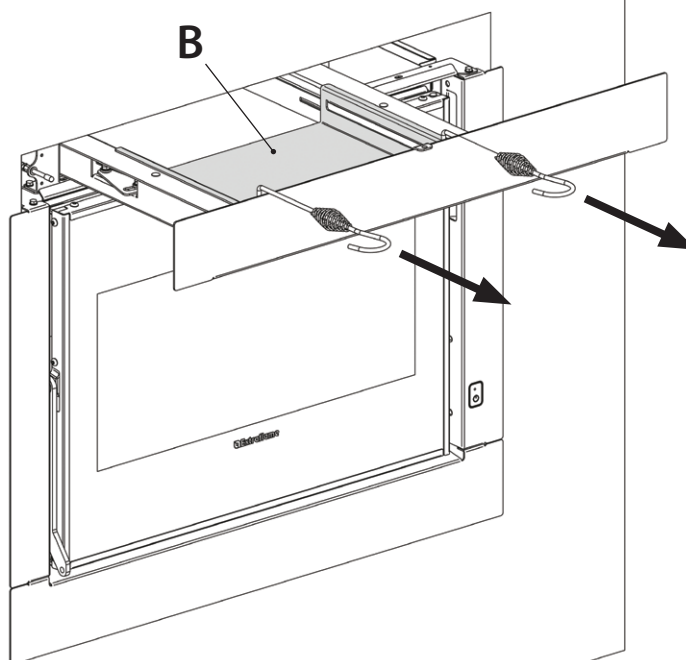

C Charger les granulés dans le tiroir et utiliser les râteau fourni pour le pousser dans le réservoir postérieur. **Il est impératif de vider complètement les pellets du tiroir dans le réservoir postérieur!**

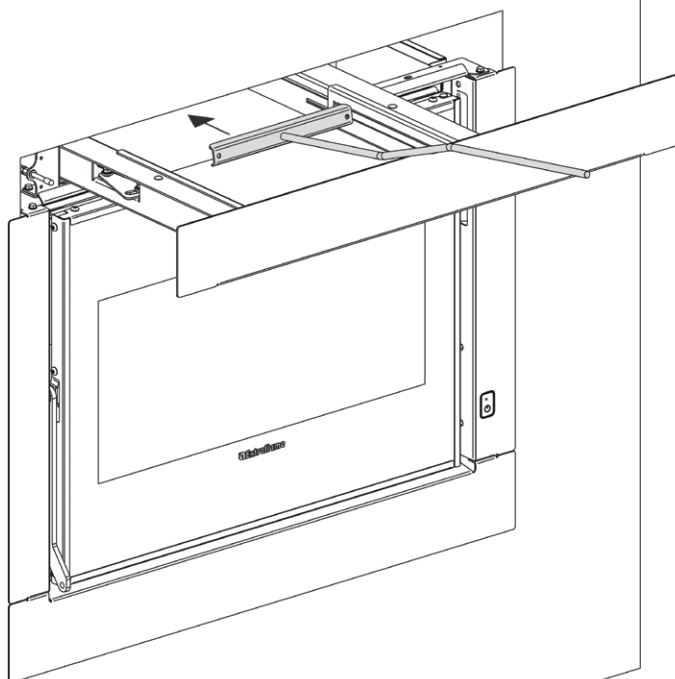

D Une fois les pellets terminés, fermez le tiroir (B) à l'aide des tisonniers fournis.

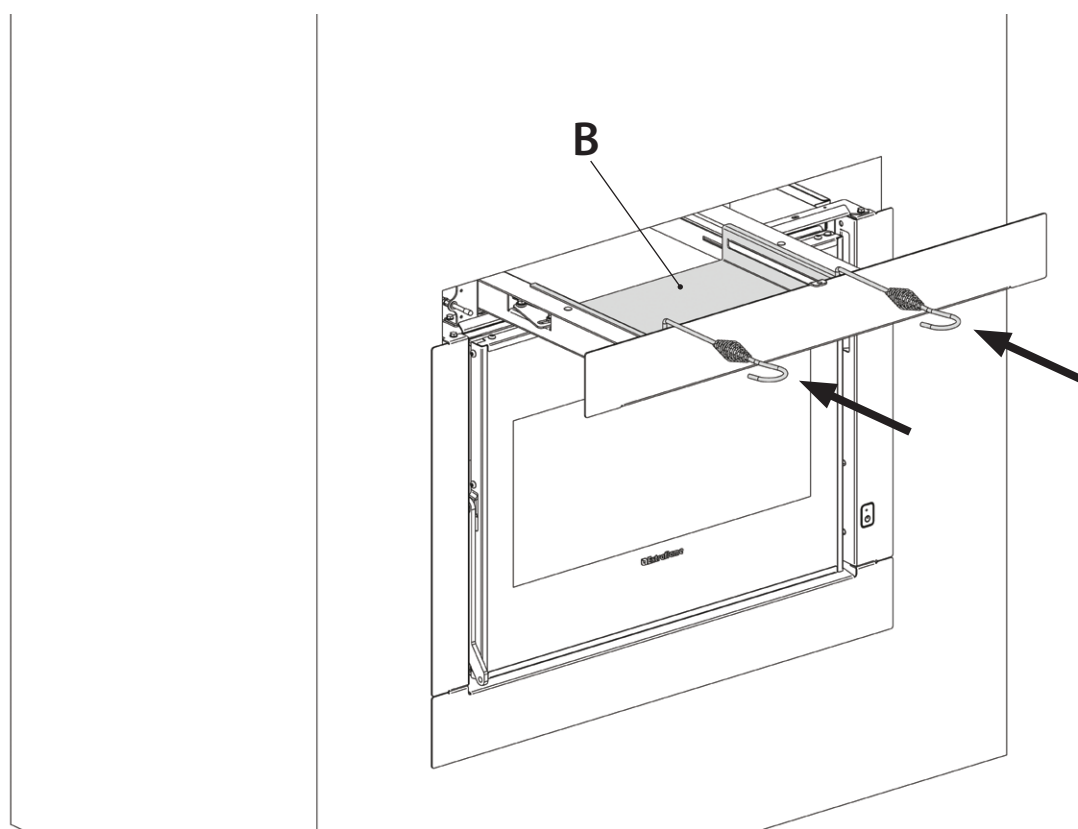

E Une fois que le tiroir (B) a été fermé, il sera possible de fermer le tiroir (A) en utilisant le tisonnier fourni.

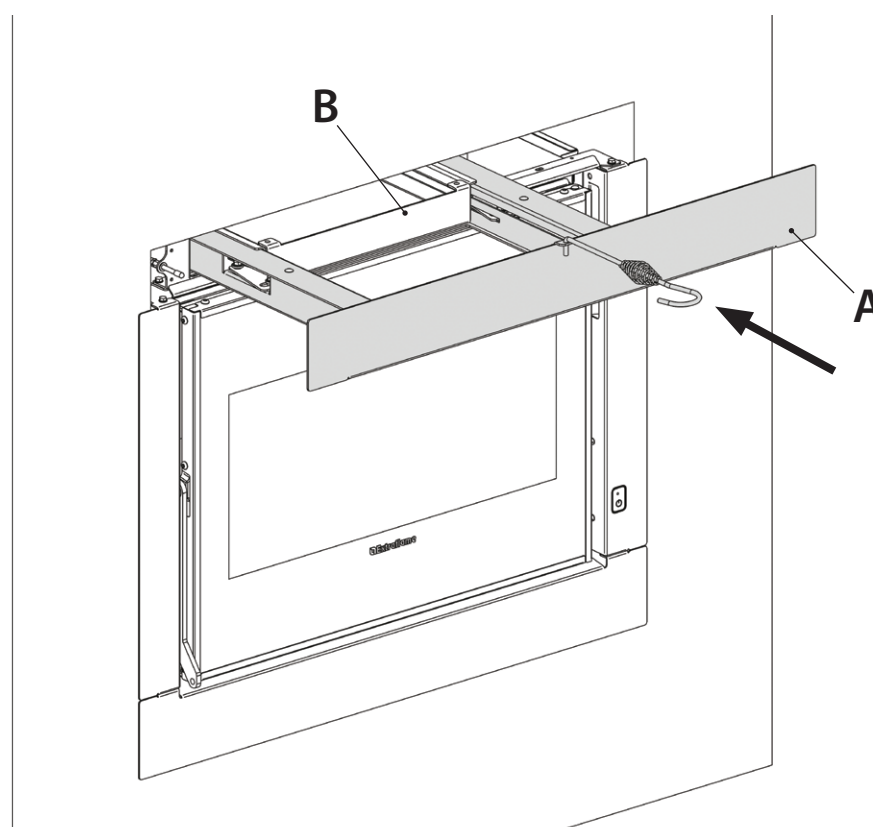

F Pour un fonctionnement correct de la cheminée, le tiroir de chargement ne doit être retiré que pendant le temps nécessaire au chargement du réservoir. Ensuite, il doit rester fermé, comme illustré.

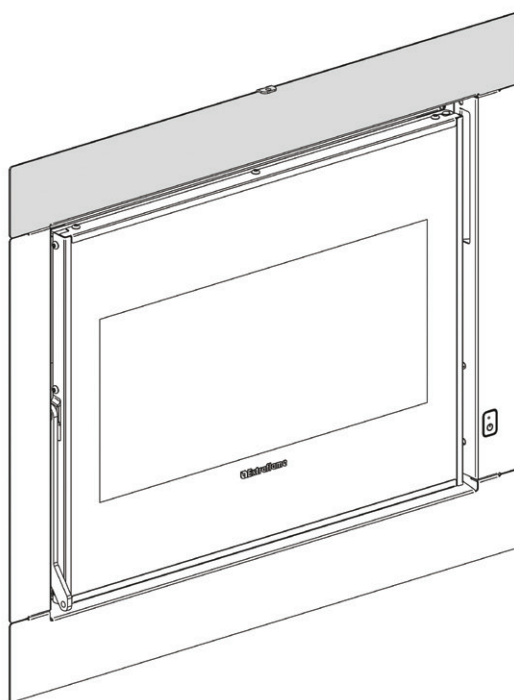

ÉLIMINATION

AU MOMENT DE L'ÉLIMINATION, CET ACCESSOIRE DOIT ÊTRE SÉPARÉ DU PRODUIT PRINCIPAL SUR LEQUEL IL ÉTAIT INITIALEMENT INCLUS, ET DOIT ÊTRE ÉLIMINÉ SÉPARÉMENT CONFORMÉMENT AUX RÉGLEMENTATIONS NATIONALES RELATIVES À SON TYPE DE MATÉRIEL.

OPTIONALES KIT ZUM FRONTALEN LADEN DER PELLETS

Das optionale Kit zum Laden der Pellets erlaubt, sie in das Innere des Tanks zu laden, ohne den Einsatz herausnehmen zu müssen (Vorgang, der das Abschalten des Geräts erfordert).

Bevor die Installation des Geräts vorgenommen wird, ist es notwendig, sich zu versichern, dass die Struktur, die den Einsatz umgeben wird, eine Öffnung mit den in der folgenden Abbildung angegebenen Mindestausmaßen gewährleistet.

In den Abbildungen werden die zu beachtenden Mindestmaße zwischen Einsatz und Verkleidung aufgeführt: Diese Maße sind notwendig, um die korrekte Bewegung des Rahmens und seine Entfernung von der ursprünglichen Position zu erlauben.

Die Montage ist auch bei montiertem Einsatz möglich.

COMFORT P70 AIR H49 - COMFORT P70 AIR H49 5.0

550 X 700 MM MIT OPTIONALER SCHUBLADE

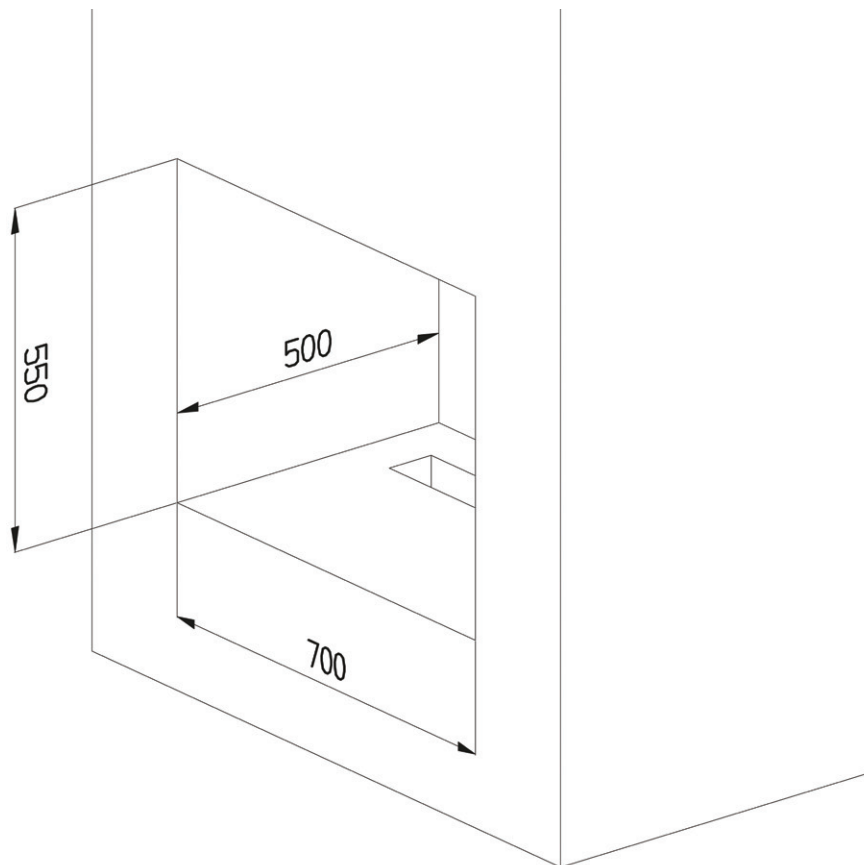

ACHTUNG:

**DIE ANWEISUNGEN IMMER IN GRÖSSTMÖGLICHER SICHERHEIT AUSFÜHREN!
DER OFEN MUSS VOLLKOMMEN KALT, ABGESCHALTET
UND VOM STROMNETZ ABGETRENNT SEIN.**

**FÜR EINE KORREKTE FUNKTIONSWEISE DES EINSATZES MUSS DIE SCHUBLADE IMMER
GESCHLOSSEN BLEIBEN, MIT AUSNAHME DER PHASE DES LADENS DES TANKS.**

**ES WIRD EMPFOHLEN, BEZÜGLICH DER MENGE AN PELLETS DIE KAPAZITÄT
DES TANKS NICHT ZU ÜBERSCHREITEN, UM ZU VERMEIDEN, DASS PELLETS IN DAS INNERE DES PRODUKTS FALLEN**

KOMPONENTEN DES KIT

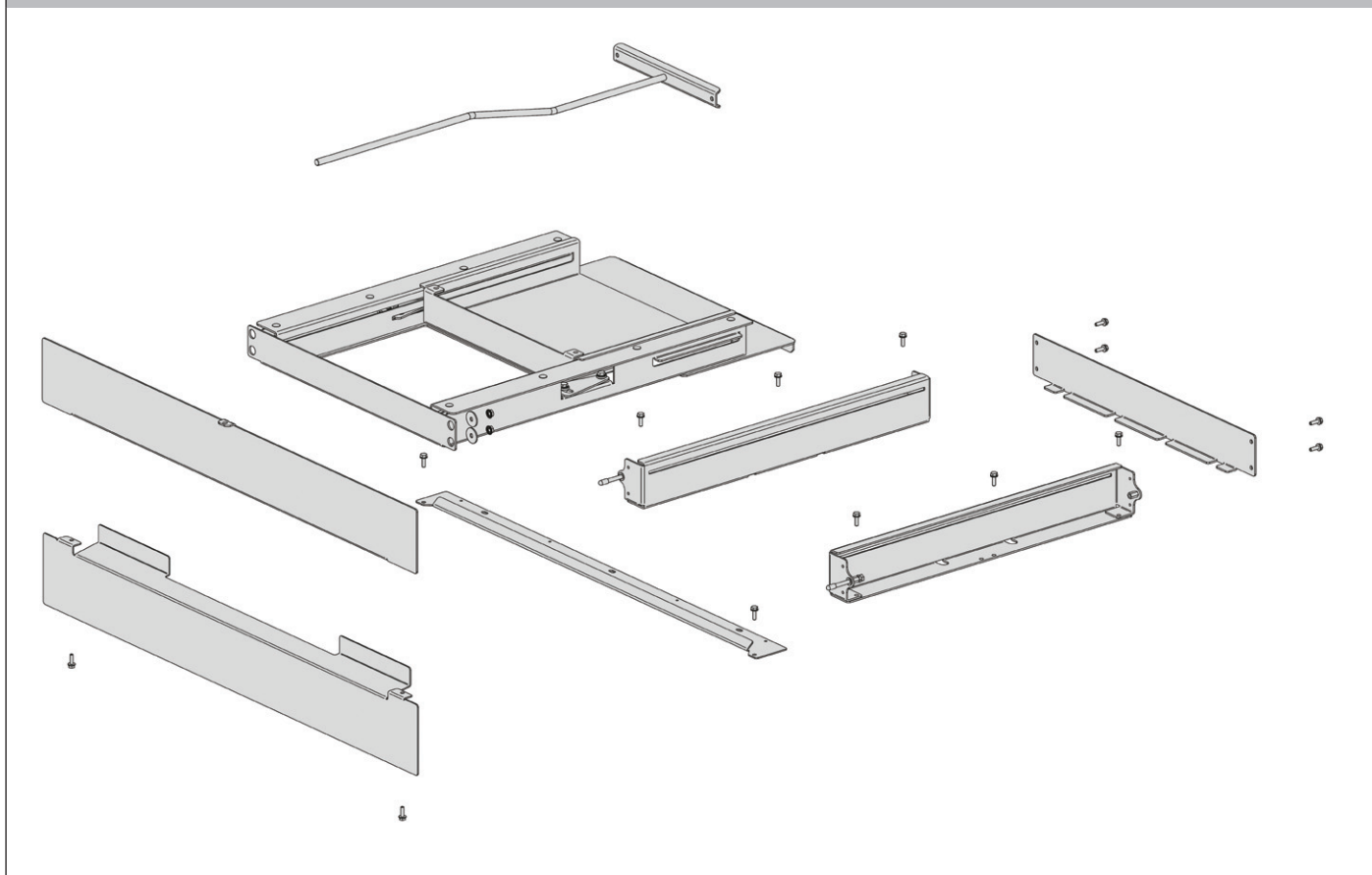

1 Entfernen Sie den Frontrahmen

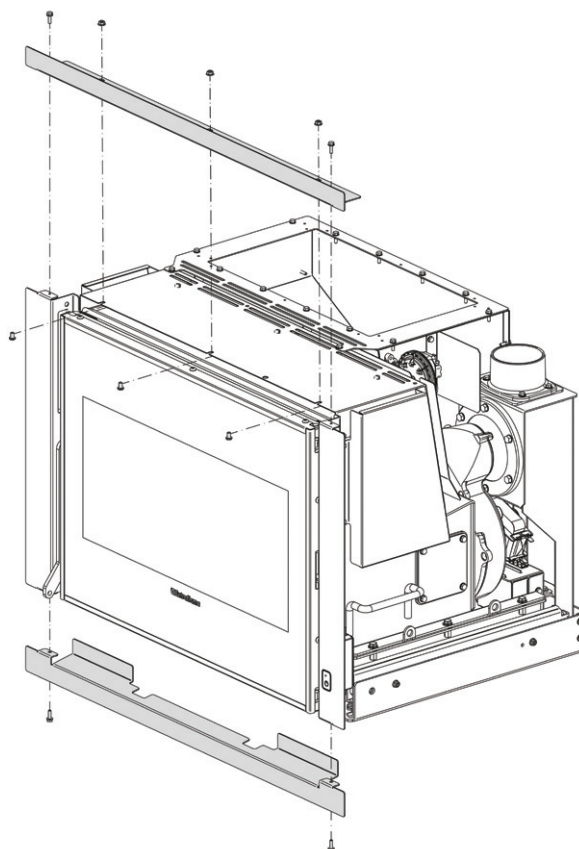

2 Installieren Sie den gelieferten Rahmen

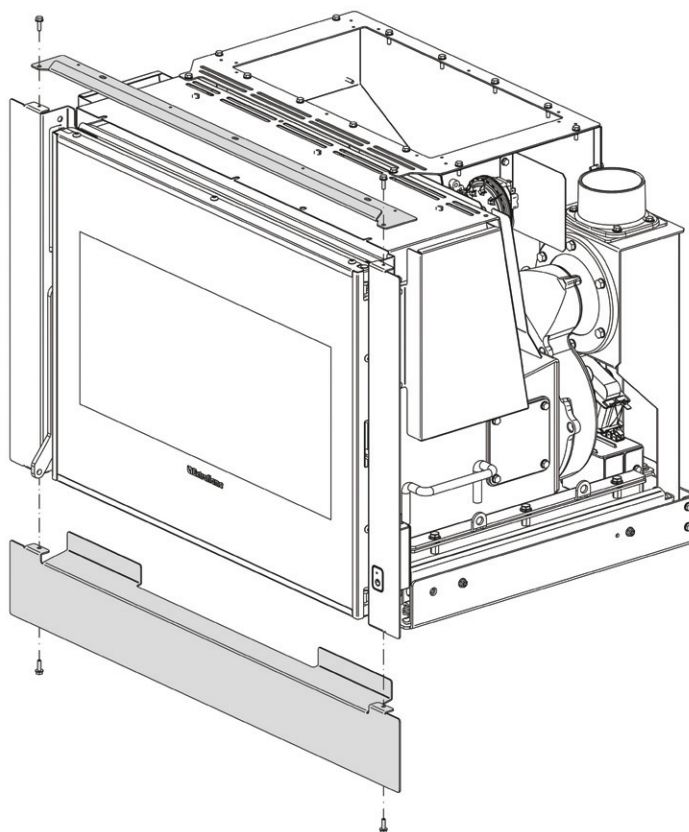

3 Rechte Schiene befestigen

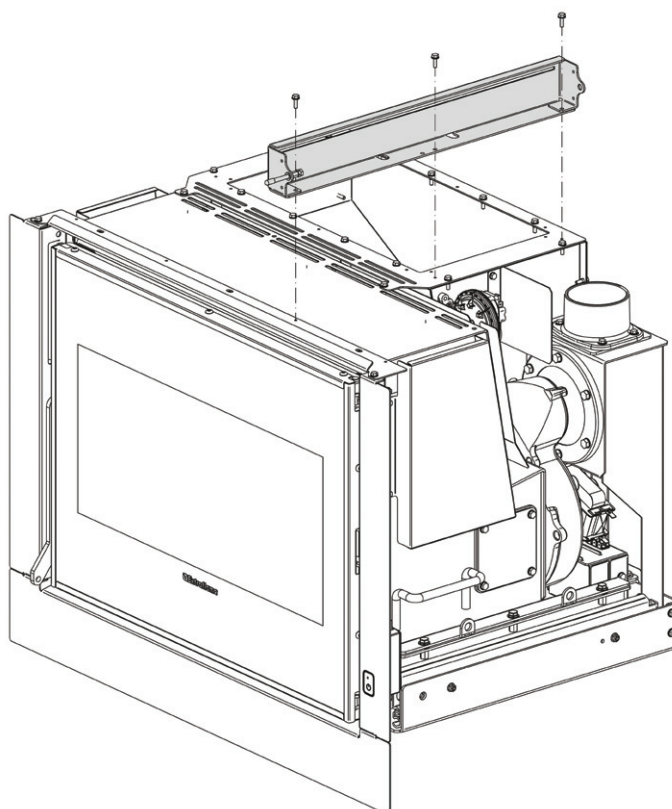

4 Schublade und die linke Schiene zusammensetzen

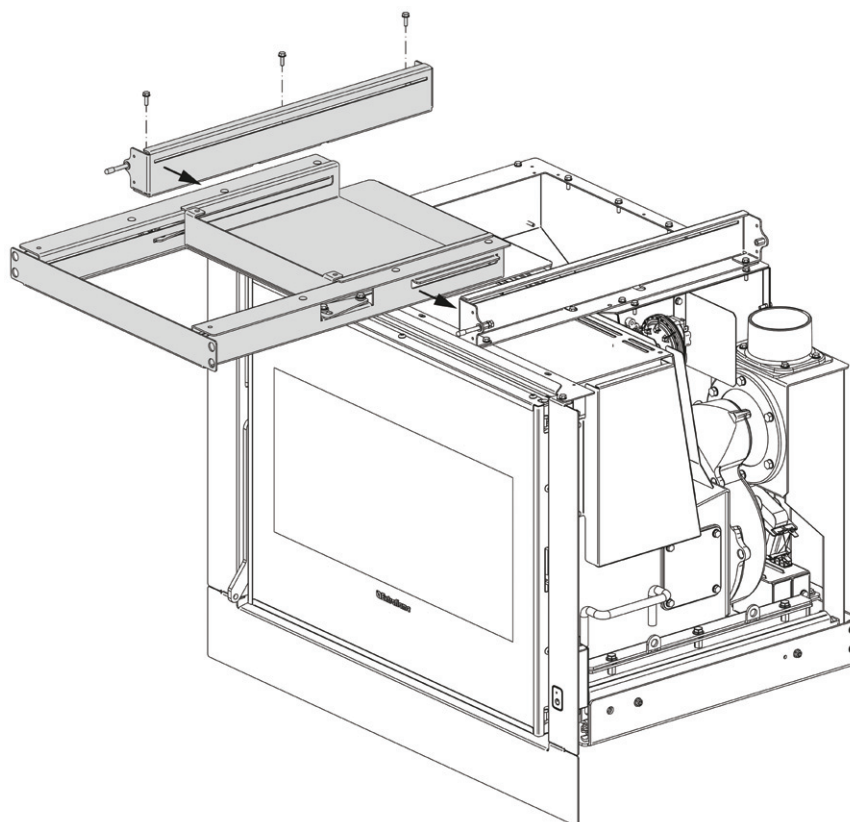

5 Linke Schiene und hintere Verstärkung befestigen.

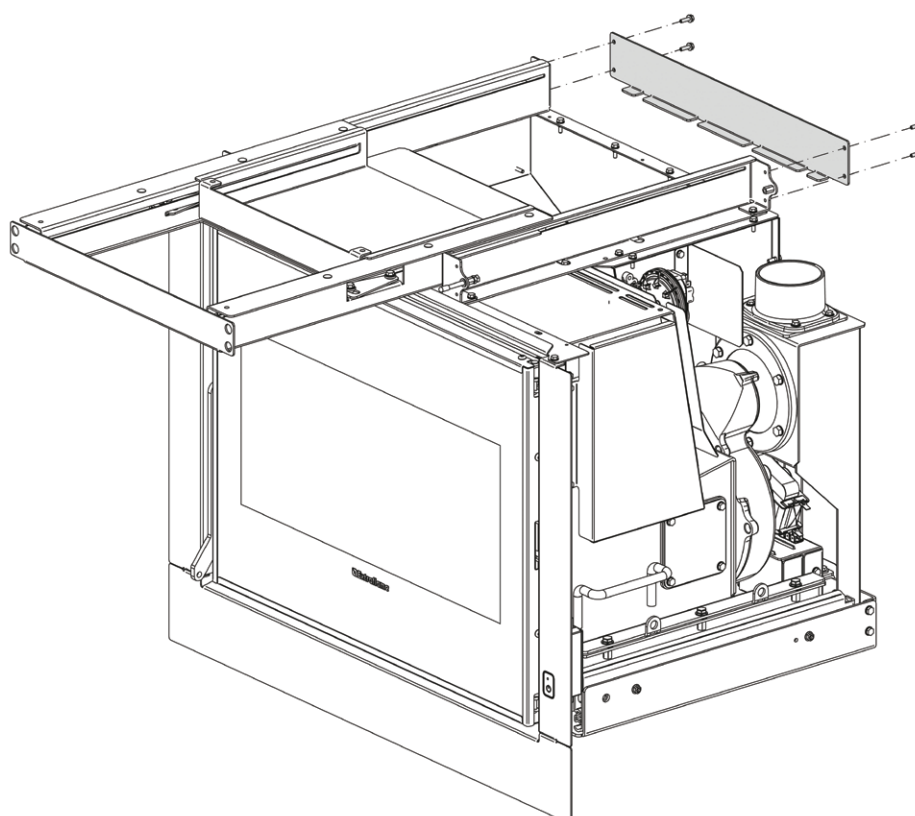

6 Befestigen Sie den Frontrahmen

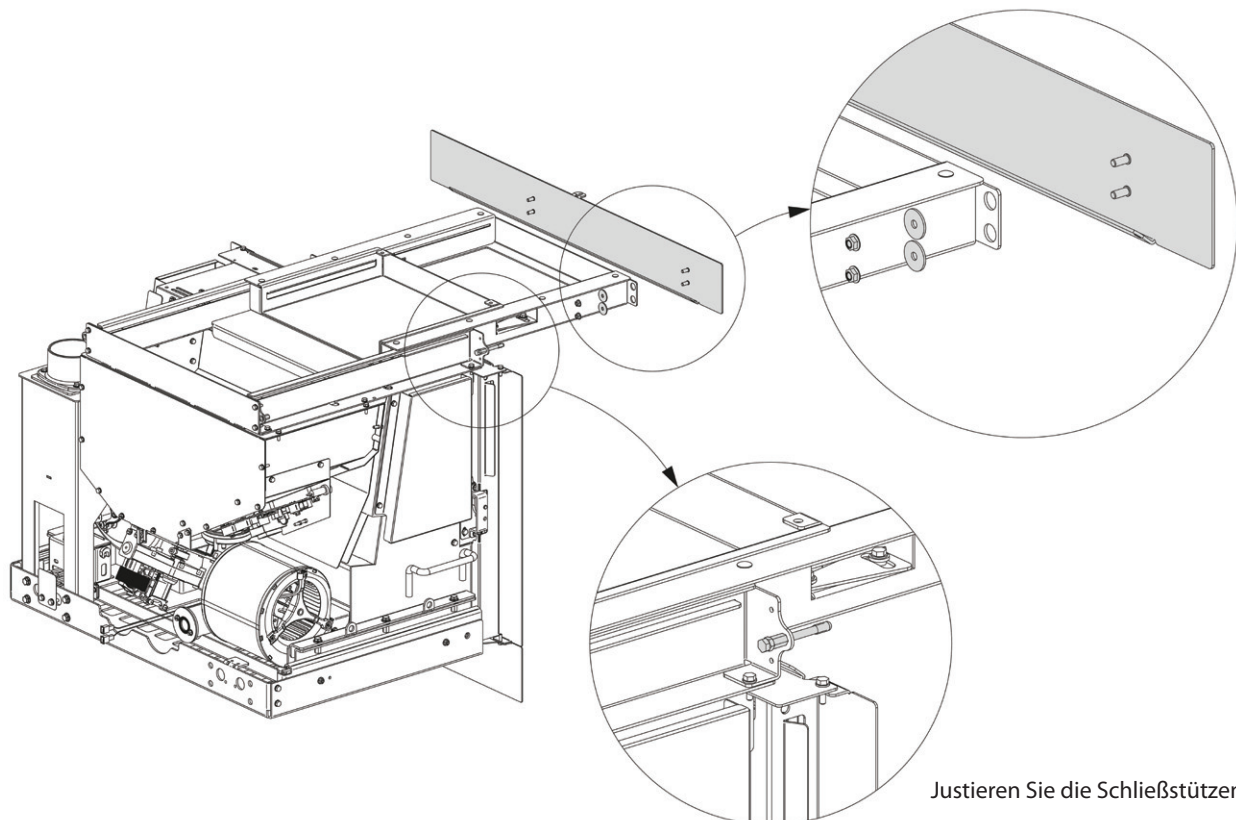

GEBRAUCH DER SCHUBLADE

A Ziehen Sie die Schublade (A) bis zur maximalen Verlängerung heraus, mit Hilfe des Schürhakens.

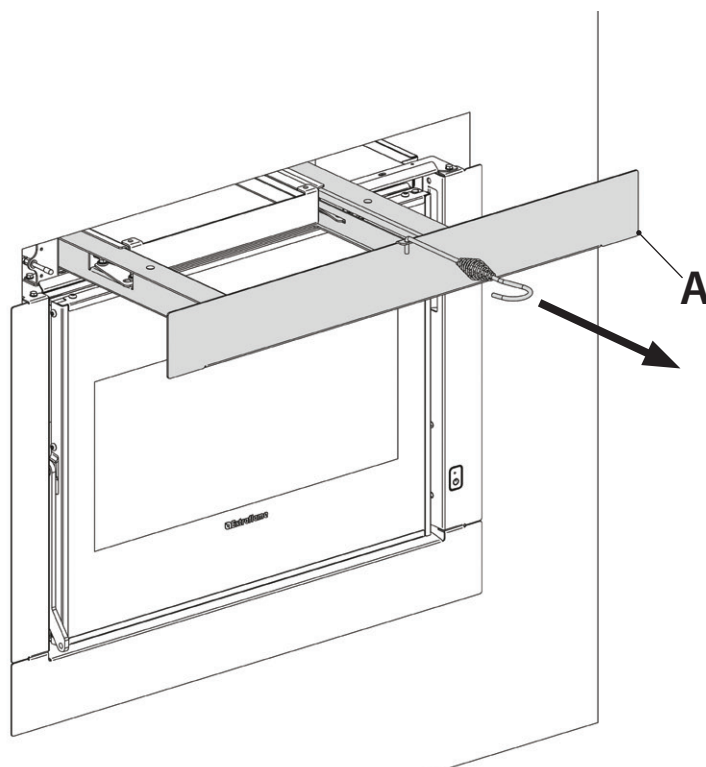

B

Ziehen Sie die Schublade (B) bis zur maximalen Verlängerung heraus, mit Hilfe des Schürhakens.

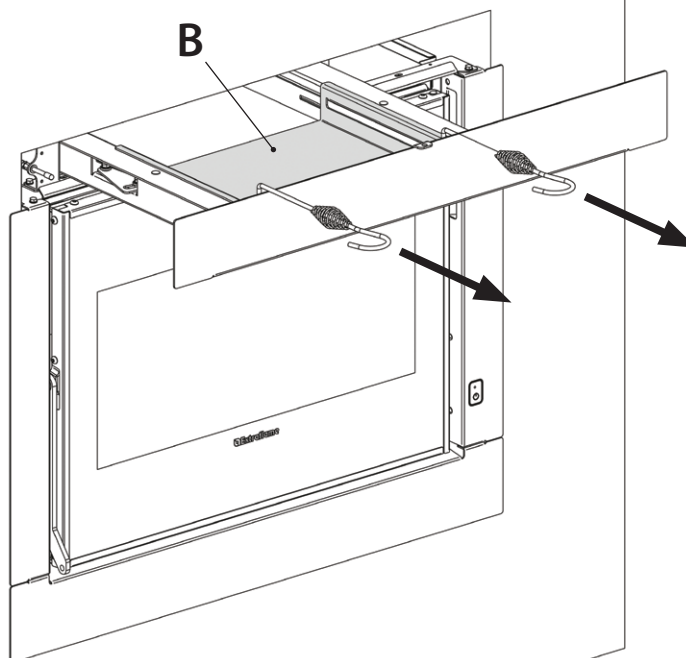

C

Die Pellets in die Schublade laden und den Schaber in der Ausstattung verwenden, um sie in den dahinter liegenden Tank zu schieben. **Die Pellets müssen unbedingt vollständig aus der Schublade bis zum dahinter liegenden Tank entleert werden!**

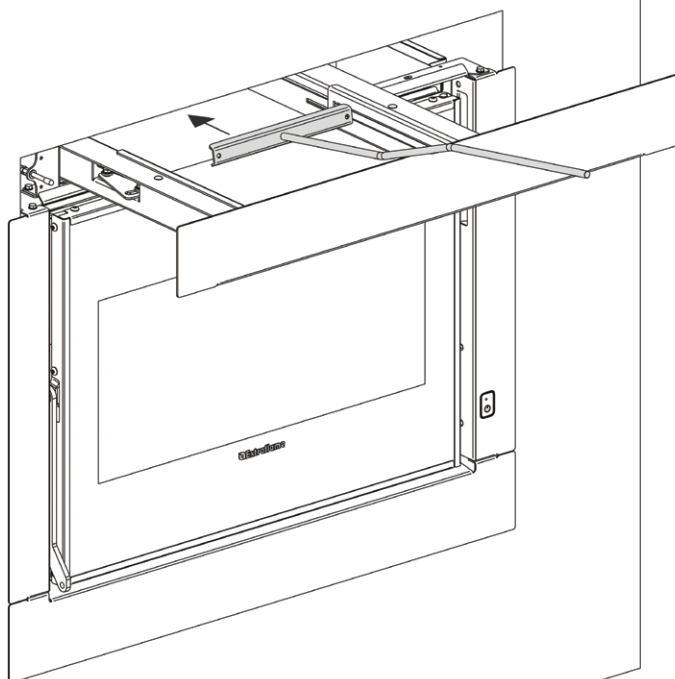

D

Nach dem Laden des Pellets Schließen Sie die Schublade (B) mit den mitgelieferten Schürhaken.

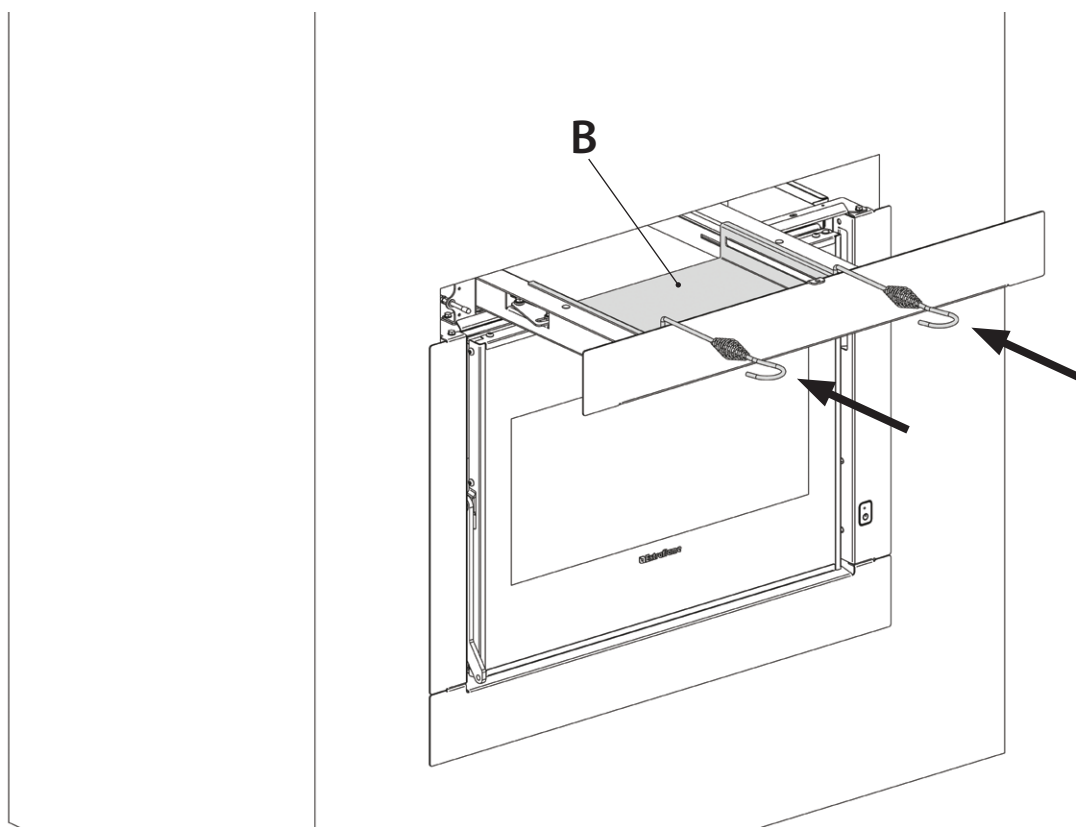

E

Sobald die Schublade (B) geschlossen ist, kann die Schublade (A) mit der mitgelieferten Schürhaken geschlossen werden.

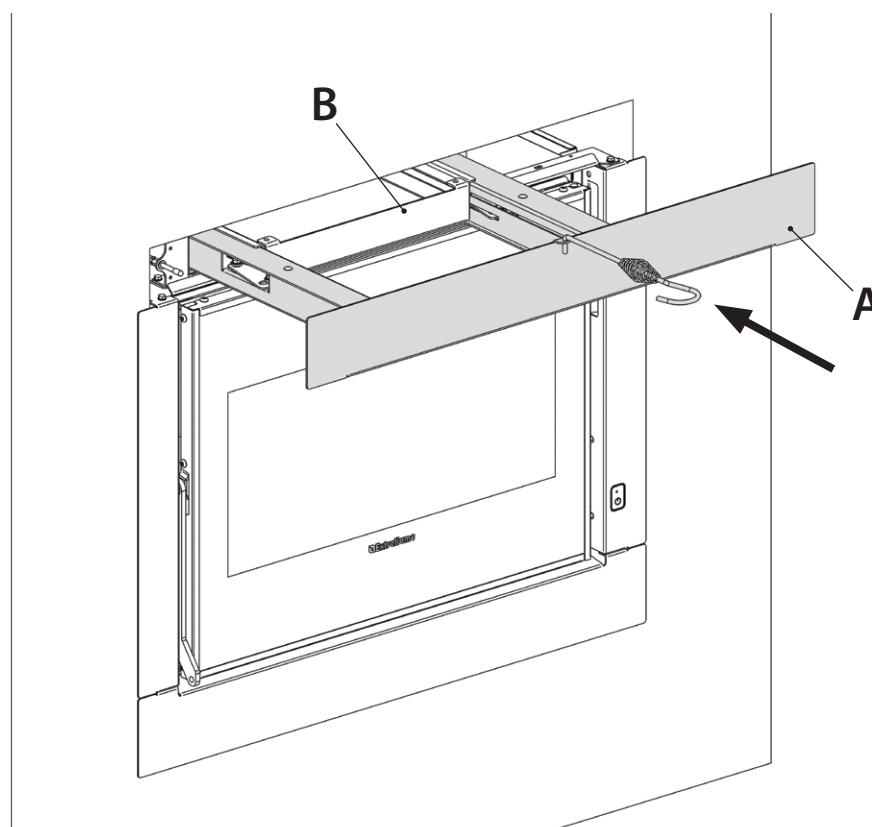

F Für einen korrekten Betrieb des Einsatzes, muss die Schublade nur für erforderliche Zeit benutzt werden, den Tank auszufüllen.

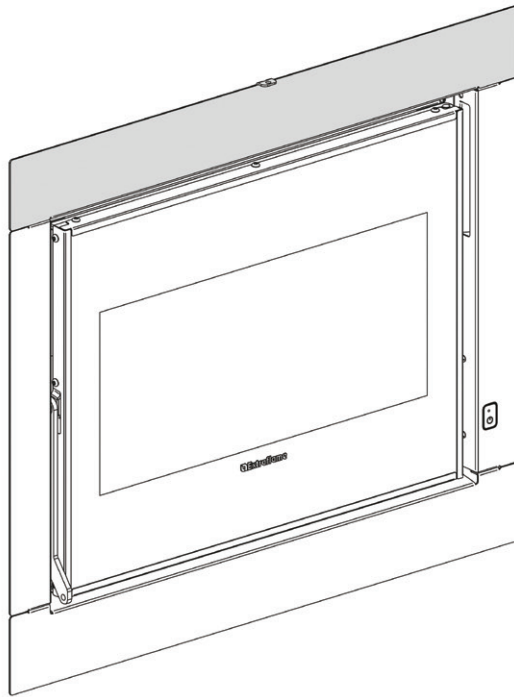

BESEITIGUNG

BEI DER ENTSORGUNG MUSS DIESES ZUBEHÖRTEIL VON DEM HAUPTPRODUKT, DEM ES URSPRÜNGLICH BEIGEFÜGT WAR, GETRENNT WERDEN UND IST GEMÄSS DEN NATIONALEN VORSCHRIFTEN FÜR DIE JEWEILIGE MATERIALART GETRENNT ZU ENTSORGEN.

KIT OPCIONAL CARGA PELLETT FRONTAL

El kit opcional de carga del pellet permite cargar frontalmente el pellet en el interior del depósito sin tener que extraer el inserto (operación que requiere el apagado de la máquina).

Antes de instalar el aparato es necesario asegurarse de que la estructura que revestirá el inserto garantiza un agujero con las medidas mínimas, que se indican en las imágenes de abajo.

En las imágenes aparecen las medidas mínimas que deben respetarse entre el inserto y el revestimiento: dichas medidas son necesarias para que el marco se mueva correctamente y para poder extraerlo de su lugar originario.

El montaje se puede realizar también con el inserto montado.

COMFORT P70 AIR H49 - COMFORT P70 AIR H49 5.0

550 X 700 MM CON CAJÓN OPCIONAL

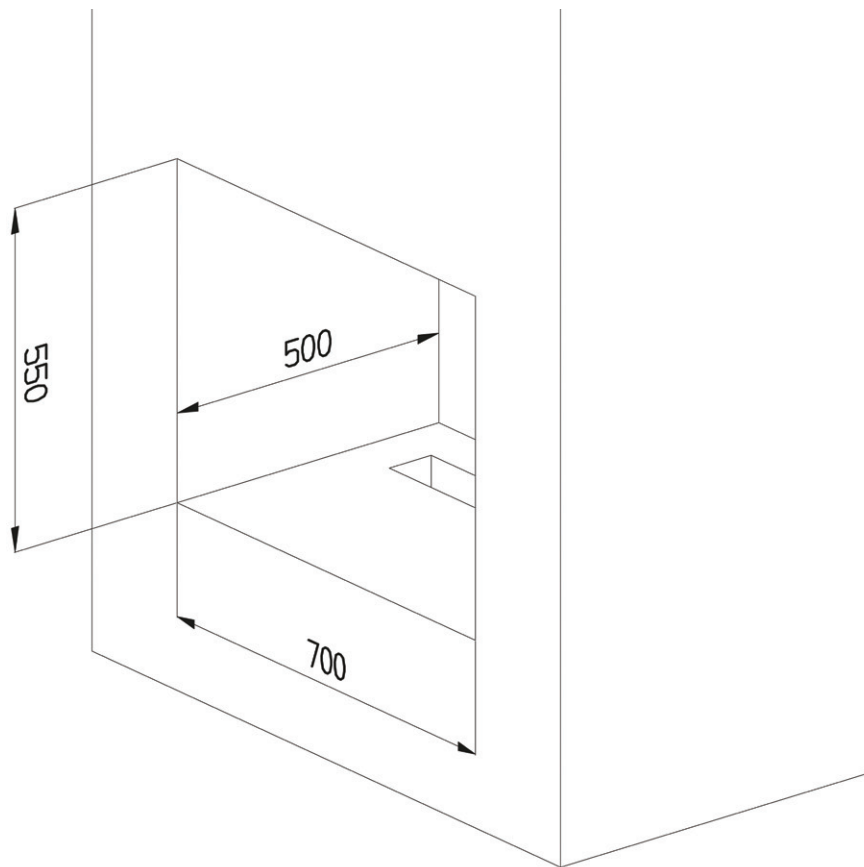

ATENCIÓN:

**¡SIGA LAS INDICACIONES SIEMPRE CON LA MÁXIMA SEGURIDAD!
LA ESTUFA DEBE ESTAR COMPLETAMENTE FRÍA, APAGADA
Y DESCONECTADA DE LA TOMA ELÉCTRICA DE RED.**

**PARA QUE EL INSERTO FUNCIONE CORRECTAMENTE, EL CAJÓN DEBE ESTAR SIEMPRE
CERRADO, SALVO DURANTE LA FASE DE CARGA DEL DEPÓSITO.**

**SE RECOMIENDA NO CARGAR UNA CANTIDAD DE PELLETT SUPERIOR A LA CAPACIDAD
DEL DEPÓSITO Y EVITE QUE CAIGA PELLETT DENTRO DEL PRODUCTO**

COMPONENTES DEL KIT

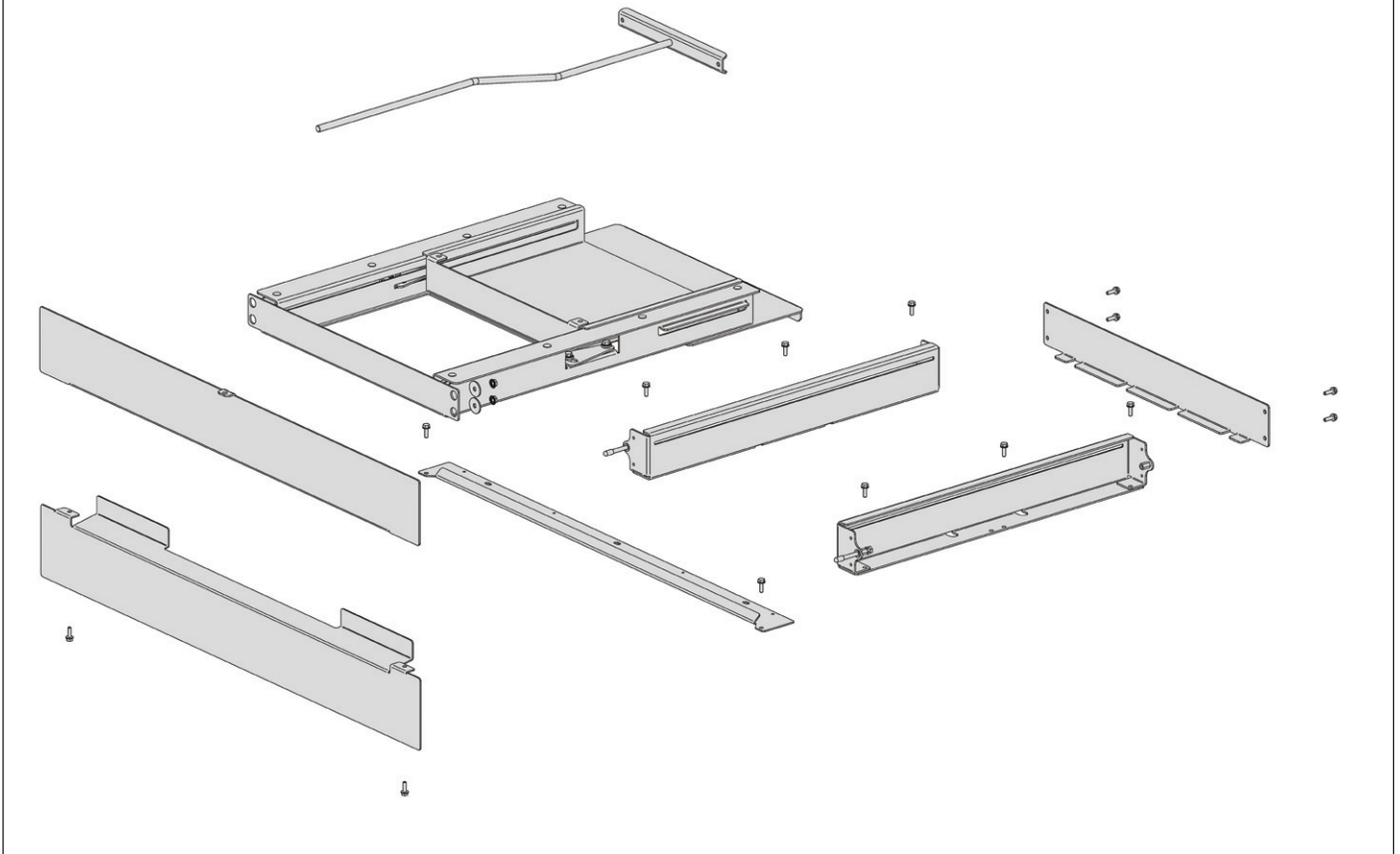

1 Retire el marco frontal

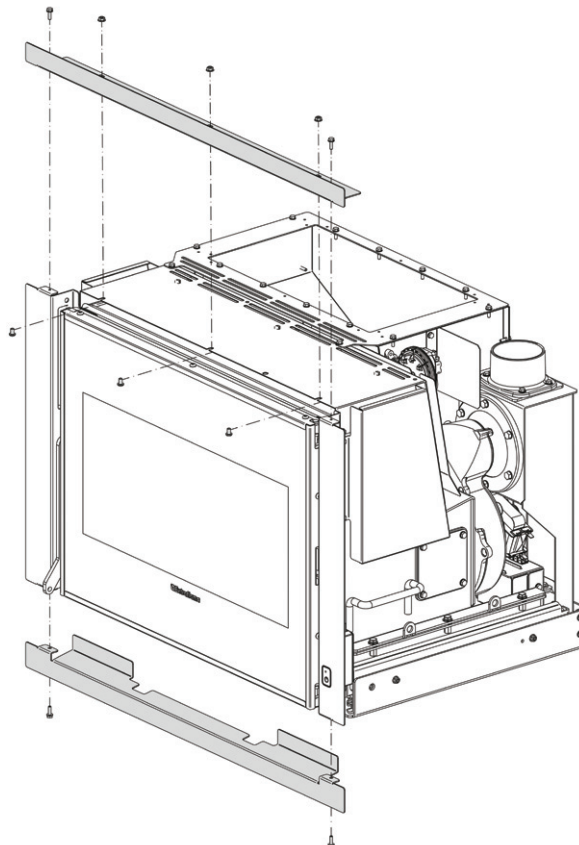

2 Instale los marcos suministrados con el kit

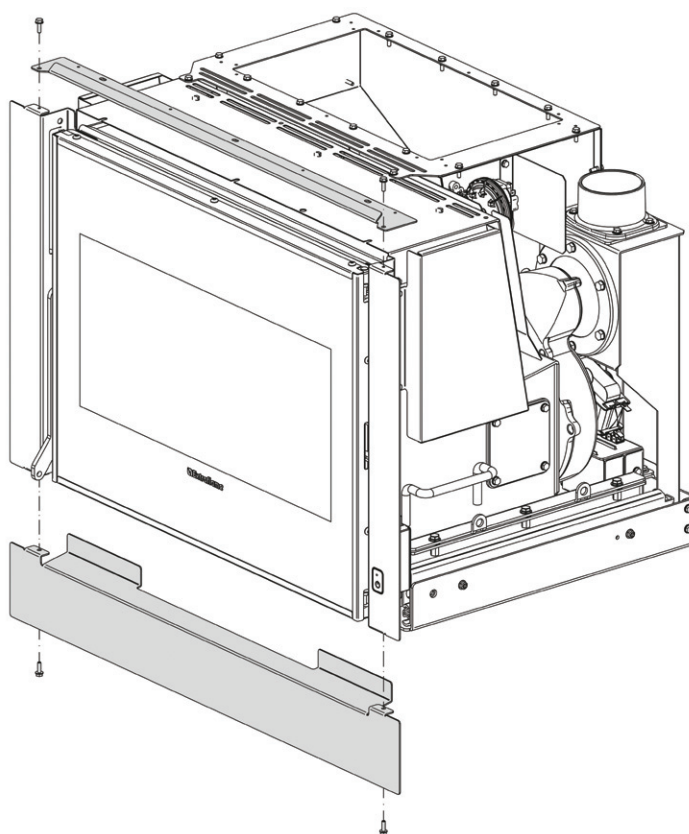

3 Sujetar el rail derecho

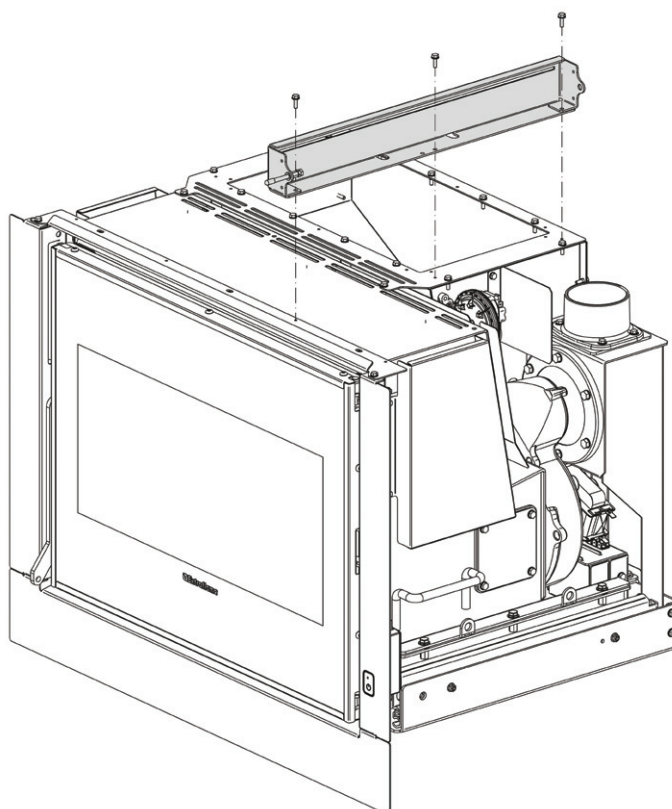

- 4 Inserte el cajón y el rail izquierdo.

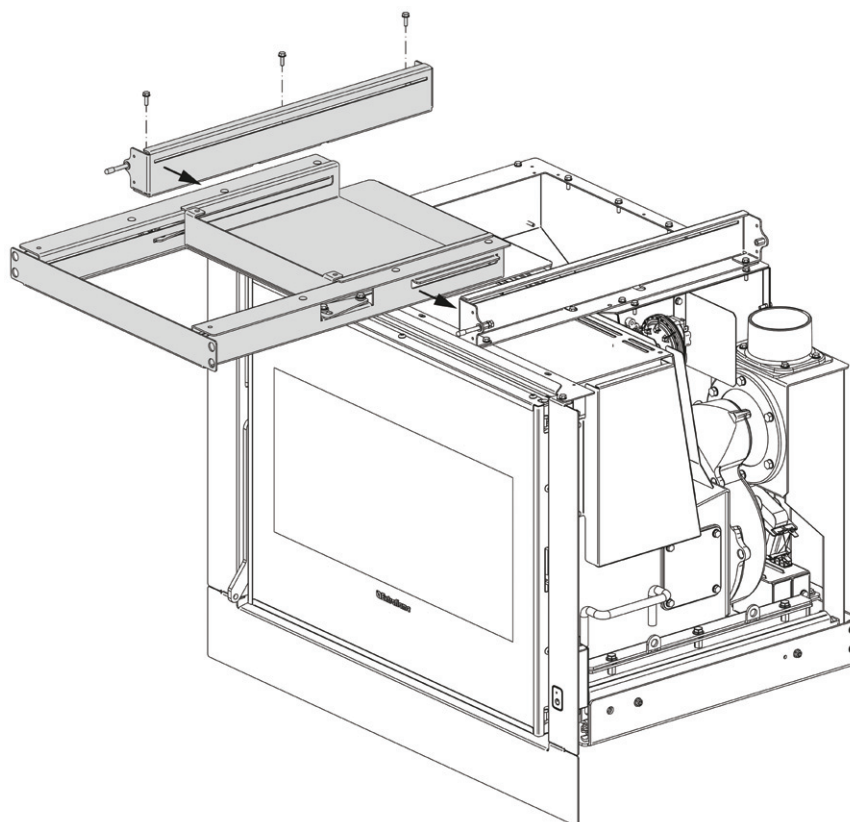

- 5 Fije el rail izquierdo y el refuerzo trasero.

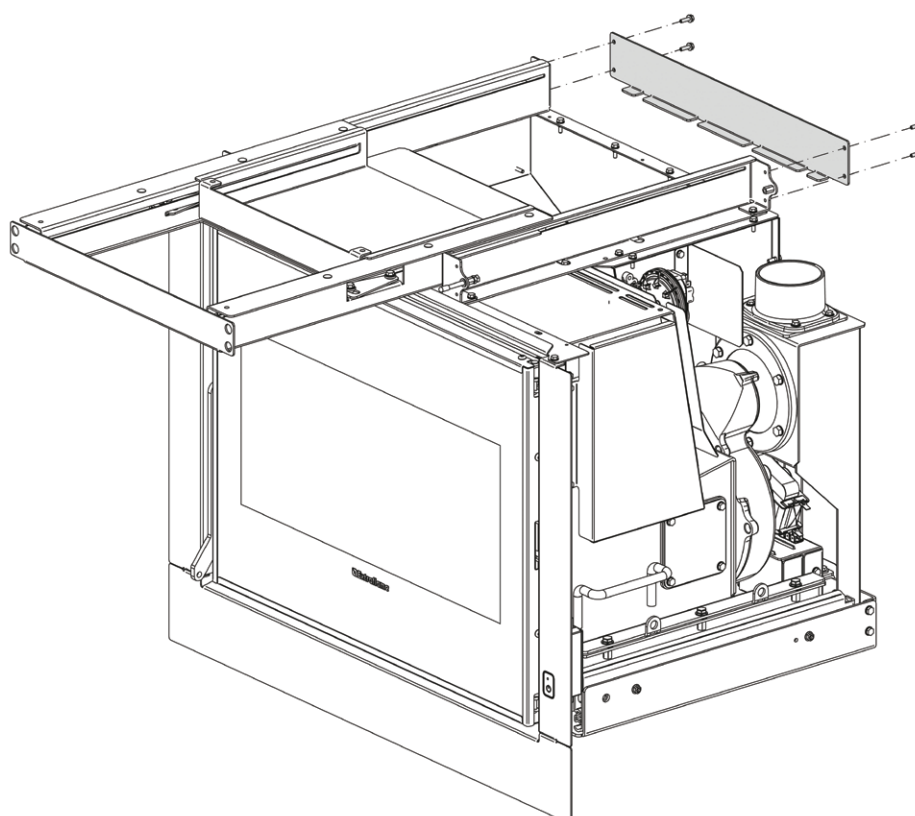

6 Arreglar el marco estético.

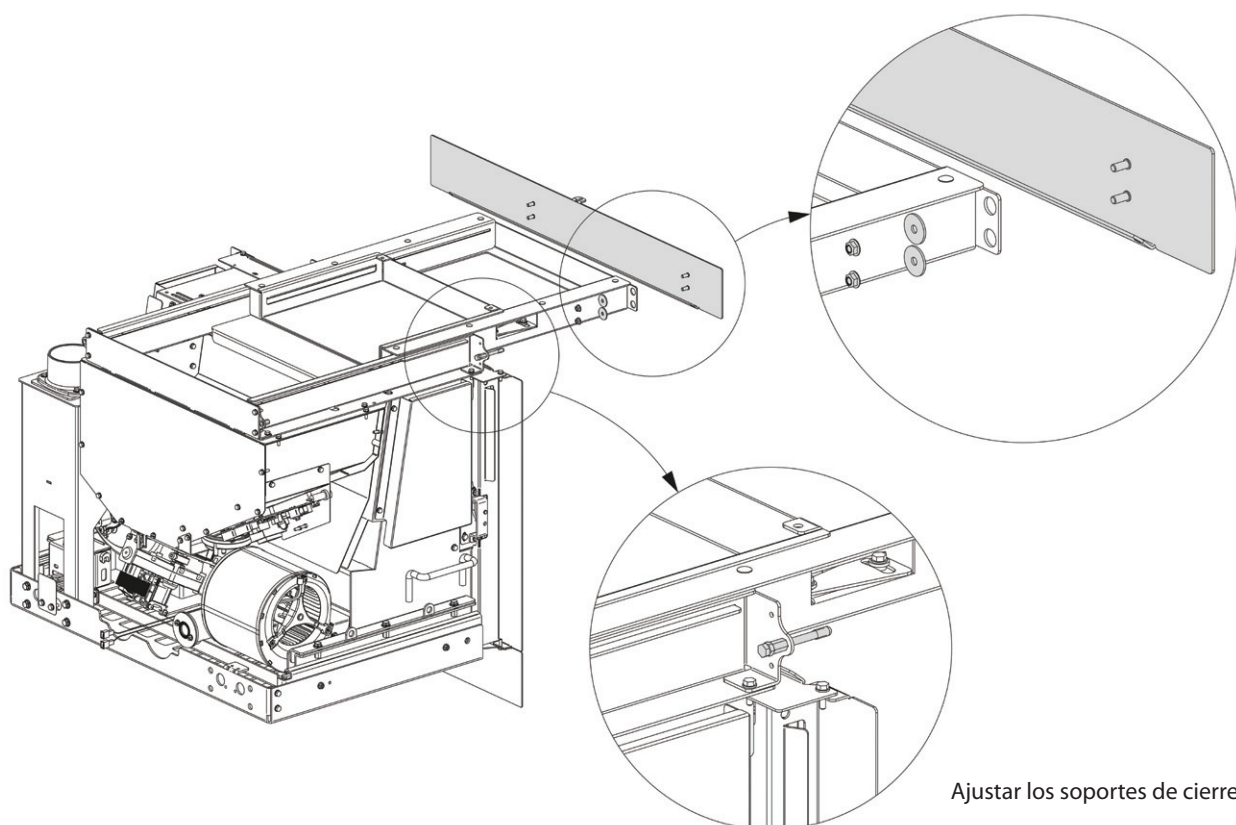

UTILIZACIÓN DEL CAJÓN

A Saque el cajón (A) hasta la extensión máxima, utilizando el atizador suministrado.

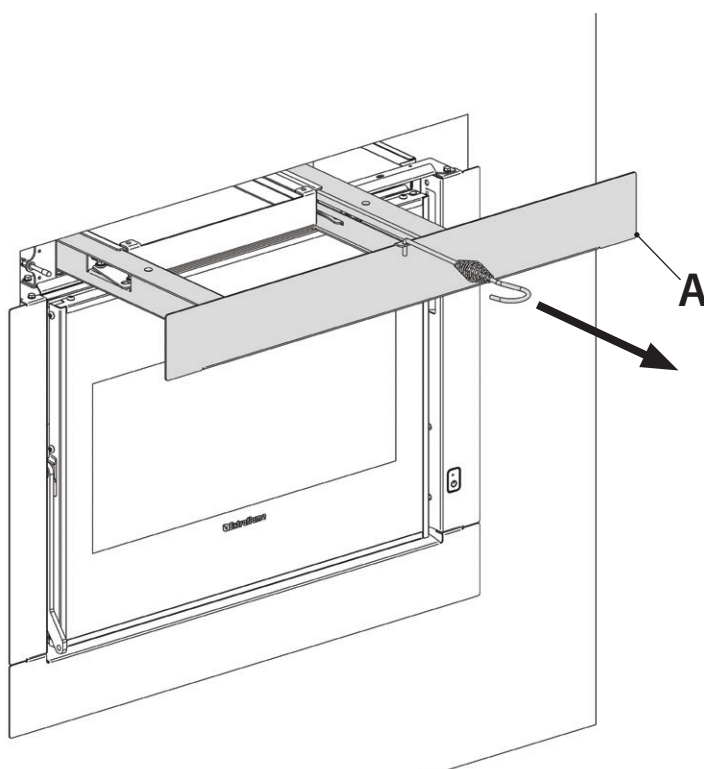

B Saque el cajón (B) hasta la extensión máxima, utilizando el atizador suministrado.

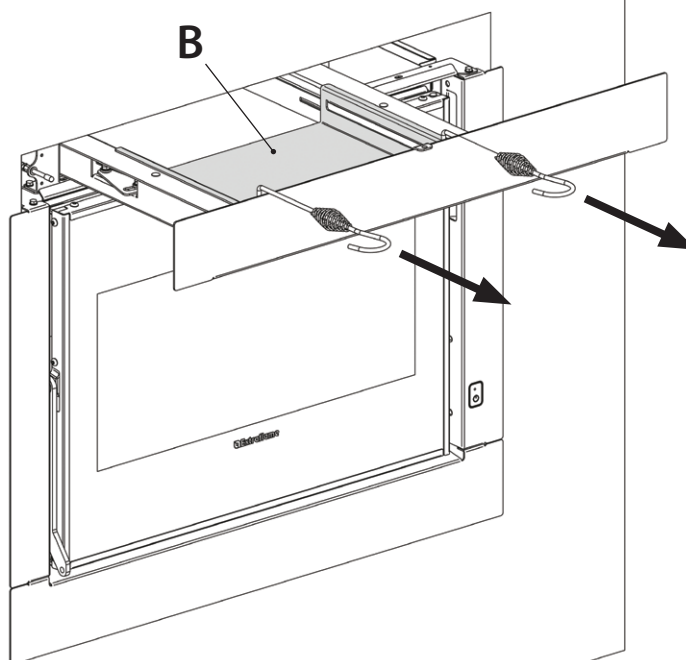

C Cargue los granulos en el cajón y use el rastrillo suministrado para empujarlo en el deposito posterior.
¡Es imperativo vaciar por completo el pellet del cajón al deposito trasero!

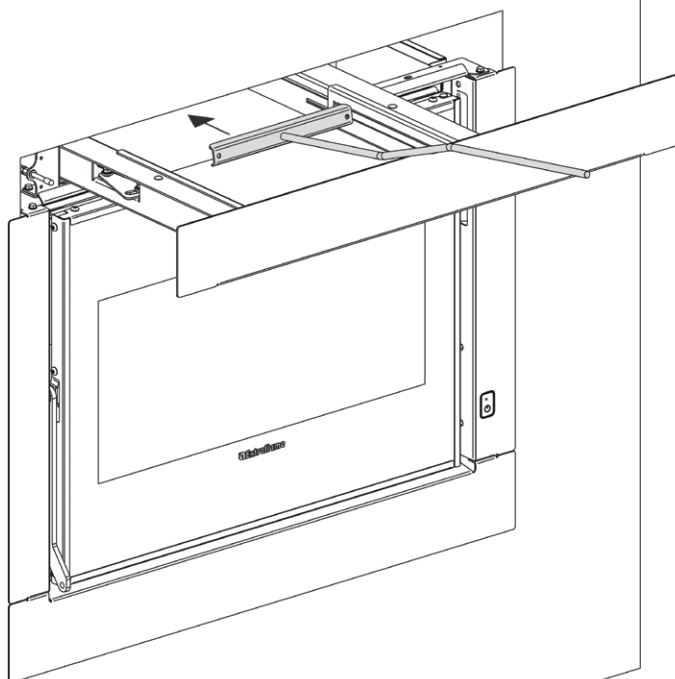

D

Cuando haya terminado con los pellets, cierre el cajón (B) con los atizador suministrados.

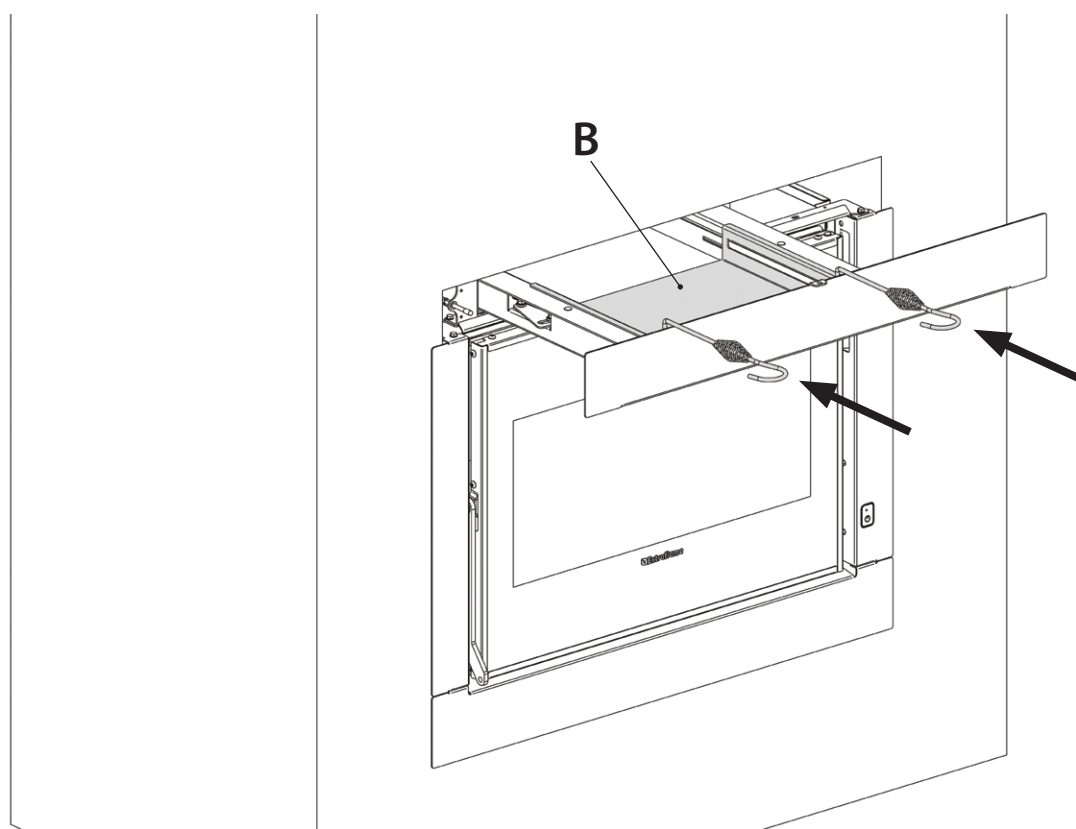

E

Una vez que se haya cerrado el cajón (B), será posible cerrar el cajón (A) utilizando el atizador suministrado.

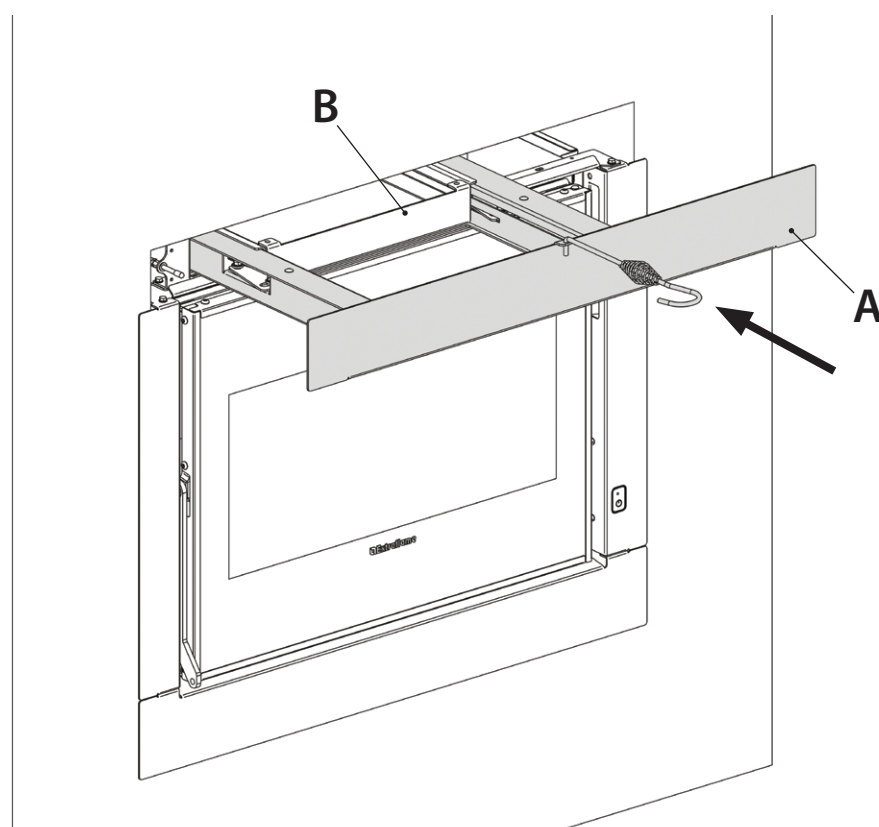

F Para un correcto funcionamiento de la chimenea, el cajón de carga solo debe retirarse por el tiempo necesario, cuando se carga el tanque. Sino, por todo el tiempo debe permanecer cerrado como da imagen.

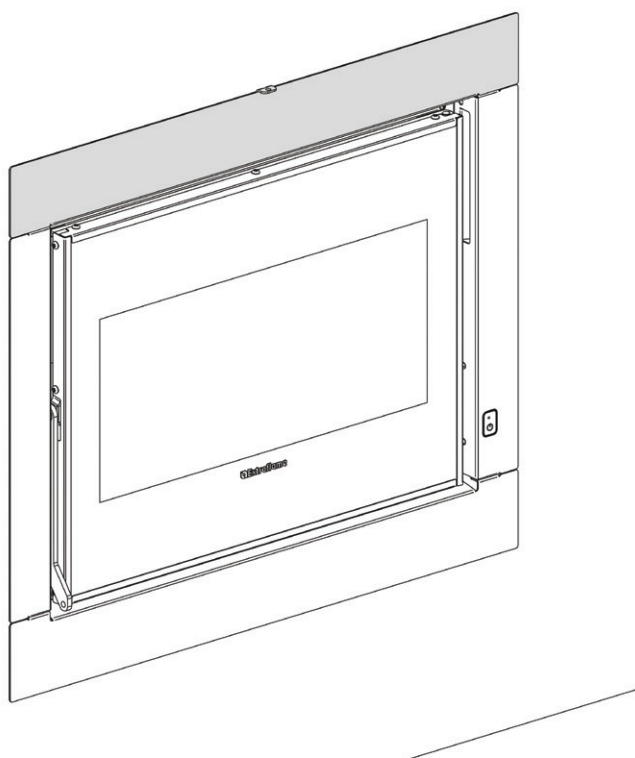

ELIMINACIÓN

EN EL MOMENTO DE LA ELIMINACIÓN, ESTE ACCESORIO DEBE SEPARARSE DEL PRODUCTO PRINCIPAL EN EL QUE SE INCLUYÓ ORIGINALMENTE, Y DEBE ELIMINARSE POR SEPARADO DE ACUERDO CON LAS NORMAS NACIONALES RELATIVAS A SU TIPO DE MATERIAL.

Extraflame®

Riscaldamento a Pellet

EXTRAFLAME S.p.A. Via Dell'Artigianato, 12 36030 - MONTECCHIO PRECALCINO (VI) - ITALY

☎ +39.0445.865911 - 📠 +39.0445.865912 - ✉ info@extraflame.it - 🌐 www.lanordica-extraflame.com

MADE IN ITALY
design & production

PER CONOSCERE IL CENTRO ASSISTENZA PIÙ VICINO CONTATTARE IL PROPRIO RIVENDITORE O CONSULTARE IL SITO
WWW.LANORDICA-EXTRAFLAME.COM

TO FIND THE SERVICE CENTRE NEAREST TO YOU CONTACT YOUR DEALER OR CONSULT
THE SITE WWW.LANORDICA-EXTRAFLAME.COM

POUR CONNAÎTRE LE CENTRE D'ASSISTANCE LE PLUS PROCHE CONTACTER VOTRE REVENEUR OU CONSULTER LE SITO
WWW.LANORDICA-EXTRAFLAME.COM

NEHMEN SIE, UM IHR NÄCHSTLIEGENDES KUNDENDIENSTZENTRUM ZU KENNEN, KONTAKT MIT IHREM HÄNDLER AUF
ODER KONSULTIEREN SIE DIE WEBSEITE WWW.LANORDICA-EXTRAFLAME.COM

PARA CONOCER EL CENTRO DE ASISTENCIA MÁS CERCANO CONTACTAR A SU REVENDEDOR O CONSULTAR EL SITIO
WWW.LANORDICA-EXTRAFLAME.COM

IL FABBRICANTE SI RISERVA DI VARIARE LE CARATTERISTICHE E I DATI RIPORTATE NEL PRESENTE FASCICOLO IN
QUALUNQUE MOMENTO E SENZA PREAVVISO, AL FINE DI MIGLIORARE I PROPRI PRODOTTI.

THE MANUFACTURER RESERVES THE RIGHT TO VARY THE CHARACTERISTICS AND THE DATA REPORTED IN THIS PAMPHLET
AT ANY MOMENT AND WITHOUT NOTICE, IN ORDER TO IMPROVE ITS PRODUCTS.

LE FABRICANT SE RÉSERVE LE DROIT DE MODIFIER LES CARACTÉRISTIQUES ET LES DONNÉES REPORTÉES DANS CE
MANUEL À TOUT MOMENT ET SANS PRÉAVIS, DANS LE BUT D'AMÉLIORER SES PRODUITS.

DER HERSTELLER BEHÄLT SICH VOR, DIE IN DEN VORLIEGENDEN UNTERLAGEN WIEDERGEgebenEN EIGENSCHAFTEN
UND DATEN ZU JEDEM BELIEBIGEN ZEITPUNKT UND OHNE VORANKÜNDIGUNG ZU ÄNDERN, UM SEINE PRODUKTE ZU
VERBESSERN.

EL FABRICANTE SE RESERVA EL DERECHO A MODIFICAR LAS CARACTERÍSTICAS Y LOS DATOS CONTENIDOS EN EL
PRESENTE MANUAL Y SIN PREVIO AVISO, CON EL OBJETIVO DE MEJORAR SUS PRODUCTOS.